

# Marine Operation Manual

FSRU ALEXANDROUPOLIS



This page is intentionally left blank

# Disclaimer

This document is intended solely for informational purposes concerning LNG vessel operations at the FSRU ALEXANDROUPOLIS Facility. GASTRADE S.A. strives to ensure the accuracy and reliability of the information provided but does not guarantee its completeness or suitability for any specific operational purpose. Users of this document must independently assess the risks and operational compatibility of their vessels with terminal requirements.

Compliance with all applicable international and local maritime regulations, safety protocols, and operational guidelines remains the sole responsibility of visiting vessels and their operators. GASTRADE S.A. disclaims any liability for direct, indirect, incidental, or consequential losses arising from reliance on this document or actions taken based on its content. Operational decisions must be made with due diligence and in collaboration with relevant terminal and maritime authorities.

Prepared by DYNAMARINE on Behalf of GASTRADE

ISBN: 978-618-86159-3-9

DYNAMARINE is a member of



And has received accreditations for their STS services from LR and ABS



## Table of Contents

Disclaimer .....	3
1fn. Introduction.....	8
1.1. Scope.....	8
1.2. Definitions .....	9
1.3. List of changes.....	10
2. Terminal Description .....	11
2.1. Terminal Characteristics .....	11
2.2. Terminal Location.....	12
2.2.1. Anchoring Position .....	12
2.2.2. Exclusion Zone.....	14
2.2.3. Restricted areas and Security Zones .....	15
2.2.4. Time .....	15
2.2.5. Weather Limitations.....	16
2.2.6. Navigational Charts .....	17
2.2.7. Metocean Conditions.....	17
2.2.8. Location Assessment.....	20
2.3. General Communications.....	21
2.4. Terminal Policies.....	22
2.4.1. Drug and Alcohol Policy .....	22
2.5. Berth Approval Parameters.....	23
2.6. Fenders.....	23
2.7. Hoses.....	25
3. Approval Procedures for LNGCs .....	27
3.1. Exchange of Information – LNGC to FSRU Terminal.....	27
3.2. Exchange of Information – FSRU Terminal to LNGC.....	27
3.3. Vessel Approval Procedures .....	27
3.4. Statutory and Regulatory Compliance .....	28
3.5. Ship Compatibility .....	28
3.6. Screening and Confirmation List .....	29
3.7. Vessel Approval Certificate.....	32
3.8. Dynamic Mooring Assessment Criteria.....	32
4. Preparation & Planning .....	33

4.1.	STS Superintendent.....	33
4.2.	Joint Plan of Operations.....	34
4.3.	Toolbox meeting.....	35
4.4.	Personnel Transfer Procedures .....	36
4.5.	Hose Handling .....	37
4.5.1.	Saddles .....	38
4.5.2.	Fall Arrest System.....	39
<b>5.</b>	<b>Communications.....</b>	<b>40</b>
5.1.	General Communications.....	40
5.2.	Ship/Shore Link .....	40
5.3.	Ship/Shore Safety Checklist.....	41
<b>6.</b>	<b>Arrival Procedures for LNGCs .....</b>	<b>42</b>
6.1.	LNGC Arrival Requirements.....	42
6.1.1.	Discharging Arrangements Spool Pieces.....	42
6.2.	Pre-Arrival Procedures – LNGC.....	42
6.3.	Notification to Authorities .....	43
6.4.	Pre- Arrival Communication .....	44
6.4.1.	Departure Notice .....	44
6.4.2.	First Notice .....	44
6.4.3.	Second notice.....	45
6.4.4.	Third Notice.....	45
6.4.5.	Forth Notice .....	46
6.4.6.	Fifth Notice.....	46
6.5.	Notice of Readiness (NOR).....	47
6.6.	Mailing List .....	48
6.6.1.	For ETA reports.....	48
6.6.2.	For Compatibility Assessment.....	48
6.7.	Pilotage .....	49
6.7.1.	Pilot boarding requirements .....	49
6.8.	Tugs & Stand-by Tug.....	50
6.9.	Berthing Approach Procedures.....	50
6.9.1.	Approach Method.....	51
6.10.	Night Berthing Operations .....	56
6.11.	Procedures for calculating the berthing Energy.....	56
6.11.1.	The approaching Velocity.....	56
6.11.2.	The approaching angle.....	57
6.11.3.	Weather conditions related to fendering and berthing criteria.....	60
6.11.4.	Maximum allowable berthing energy .....	60
<b>7.</b>	<b>Mooring and Unmooring Operation.....</b>	<b>62</b>

7.1.	Mooring Plan.....	62
7.2.	General Considerations.....	63
7.3.	Mooring.....	63
7.4.	Mooring Lines Monitoring .....	64
7.5.	Unmooring .....	65
7.6.	Unberthing procedures.....	65
<b>8.</b>	<b>General Safety .....</b>	<b>67</b>
8.1.	Crew preparedness and readiness.....	67
8.2.	Engine Safety.....	67
8.3.	Repairs and Maintenance Works .....	68
8.4.	Leakage, Spillage of LNG and Fire Fighting.....	68
8.4.1.	Emergency Towing-Off Pennants .....	68
8.5.	Personnel Protective Equipment.....	69
8.6.	Environmental Considerations .....	69
8.6.1.	Blanking Unused Manifold Connections .....	70
8.6.2.	Bunkering .....	70
8.6.3.	Ballast Water Discharge .....	70
8.6.4.	Air emissions .....	70
8.6.5.	Waste Delivery .....	70
8.6.1.	Disposing Garbage Overboard .....	70
8.6.2.	External Services .....	71
8.6.3.	Bilge and Sewage Discharge.....	71
8.6.4.	LNG Leakage.....	71
8.6.5.	Water Supplies, Provisions and Spares .....	71
8.7.	Port Activities Restrictions During STS .....	71
<b>9.</b>	<b>Cargo Operation .....</b>	<b>73</b>
9.1.	Introduction .....	73
9.2.	Pre-Transfer Meeting .....	73
9.3.	Manifold Reducers .....	74
9.4.	Quick Connect Disconnect Coupling System.....	75
9.5.	Notice of Readiness to Discharge.....	75
9.6.	ESD Ship/Shore Communication Link.....	75
9.7.	Water Deluge Systems (water curtain & bath).....	76
9.8.	Manifold Restriction Access During Operations.....	77
9.9.	Pressure testing.....	77
9.10.	ESD Testing .....	77
9.11.	Cooldown .....	77
9.12.	Cargo and BOG Management .....	78
9.12.1.	Vapor Management Procedures .....	78
9.13.	End of Cargo.....	78

9.14.	Draining and Purging.....	79
9.15.	Disconnection.....	80
9.16.	Transfer of STS equipment.....	80
9.17.	Roll-Over Effects.....	80
9.18.	Cargo Measurements.....	81
9.19.	Post-Transfer Meeting.....	81
9.20.	Terminal’s Feedback Report.....	81
<b>10.</b>	<b>Emergency Procedures .....</b>	<b>82</b>
10.1.	General Considerations.....	82
10.2.	Emergency Signal.....	82
10.3.	Fire Prevention.....	82
10.4.	Emergency Communications.....	84
10.5.	Emergency Cast-Off Procedures.....	84
10.6.	Emergency Scenarios .....	86
10.6.1.	Emergency Signal.....	86
10.6.2.	Vessel Breakaway.....	86
10.6.3.	Incidents Onboard the LNGC Carrier.....	86
10.6.4.	Steering, Main Engine or Power Failure on Approach.....	87
10.6.5.	Failure of Primary or Secondary Fenders on Approach.....	87
10.6.6.	Failure of Primary or Secondary Fenders While Moored.....	88
10.6.7.	Failure of Mooring Lines.....	88
10.6.8.	Uncontrolled Release of LNGC/NG.....	90
10.6.9.	Hose Recovery Following ESD2 Event.....	91
10.6.10.	Security Breach.....	92
10.7.	Incident Reporting.....	92
<b>11.</b>	<b>References .....</b>	<b>93</b>
	<b>APPENDICES.....</b>	<b>94</b>

# 1. Introduction

## 1.1. Scope

The primary objective of this "Manual" is to delineate the protocols and guidelines that must be followed by every LNG vessel during their arrival and operations at the FSRU ALEXANDROUPOLIS situated in Alexandroupolis, Greece (referred to as the "Terminal"). This encompasses all LNGCs involved in the process.

Comprehensive in scope, this manual encompasses Terminal Regulations and pertinent information, including regulations specifically designed to ensure the safety and efficiency of operations at the FSRU Terminal. The purpose of this documentation is to furnish crucial details from the moment LNG vessels reach the pilot station to their eventual departure from the Terminal's vicinity.

Any updates to this Manual are communicated to the local Maritime Authority / Coast Guard, responsible for maritime safety, security, and environmental matters at the Terminal and Alexandroupolis, and are applicable to all relevant parties.



## 1.2. Definitions

<b>DFDE</b>	Dual Fuel Diesel Electric
<b>ERC</b>	Emergency Response Centre
<b>ESD</b>	Emergency Shut Down (as related to LNGC/shore operations)
<b>ETA</b>	Estimated Time of Arrival
<b>Exclusion Zone</b>	An exclusion zone established round the terminal within all other LNGCs and service craft are not permitted to enter
<b>FAS</b>	Fall Arrest System
<b>FSRU</b>	FSRU stands for "Floating Storage and Regasification Unit.
<b>Heel</b>	The amount of liquid LNG retained in an LNGC's cargo tank at the end of discharge
<b>IMO</b>	International Maritime Organization
<b>JPO</b>	Joint Plan of Operation
<b>LNG</b>	Liquefied Natural Gas
<b>LNGC</b>	Liquefied Natural Gas Carrier
<b>MARPOL</b>	International Convention for the Prevention of Pollution from LNGCs
<b>NOR</b>	Notice of Readiness
<b>OCIMF</b>	Oil Companies International Marine Forum
<b>OIM</b>	Offshore Installation Manager
<b>PABX</b>	Private Automatic Branch Exchange
<b>PERC</b>	Power Emergency Release Coupling
<b>Maritime Authority / Coast Guard</b>	Hellenic Coastguard
<b>SOPEP</b>	Ship Oil Pollution Emergency Plan
<b>STS</b>	Ship to Ship
<b>TAC</b>	Terminal Access Code
<b>UHF</b>	Ultra-high Frequency
<b>VHF</b>	Very High Frequency

### 1.3. List of changes

a/a	Change Description	Date	Revision
1	Initial Draft released	24/12/2023	1.00
2	Revision/addition of information	22/01/2024	1.02
3	Optimoor criteria amended, Compatibility contact added, Flag permit documents added	01/02/2024	1.03
4	Addition of Vessel Breakaway Contingency Actions	17/02/2024	1.04
5	Addition of Photos and revision of multiple sections following the completion of the Commissioning Cargo	20/03/2024	1.05
6	Addition of arrival requirements for the LNGC – Changes to guidance while alongside	10/05/2024	1.06
7	Addition of vapor management procedures	04/10/2024	1.07
8	Wording amendments	11/12/2024	1.08

## 2. Terminal Description

### 2.1. Terminal Characteristics

#### FSRU ALEXANDROUPOLIS



<b>IMO</b>	9390185
<b>Flag</b>	Greece
<b>Year of Build</b>	01/06/2010
<b>LOA</b>	288.6 m
<b>Beam</b>	44 m
<b>Depth</b>	26.2 m
<b>Deadweight</b>	86353 mt
<b>Classification Society</b>	DNV-GL
<b>P&amp;I Club</b>	Britannia Steamship insurance Association Ltd
<b>ISM/DOC Holder</b>	Gaslog LNG Services Ltd (IMO number: 5137583)

## 2.2. Terminal Location

### 2.2.1. Anchoring Position

ALEXANDROUPOLIS is stationed 17.6km Southwest from the port Alexandroupolis and 10 km from the nearest coast of Makri.

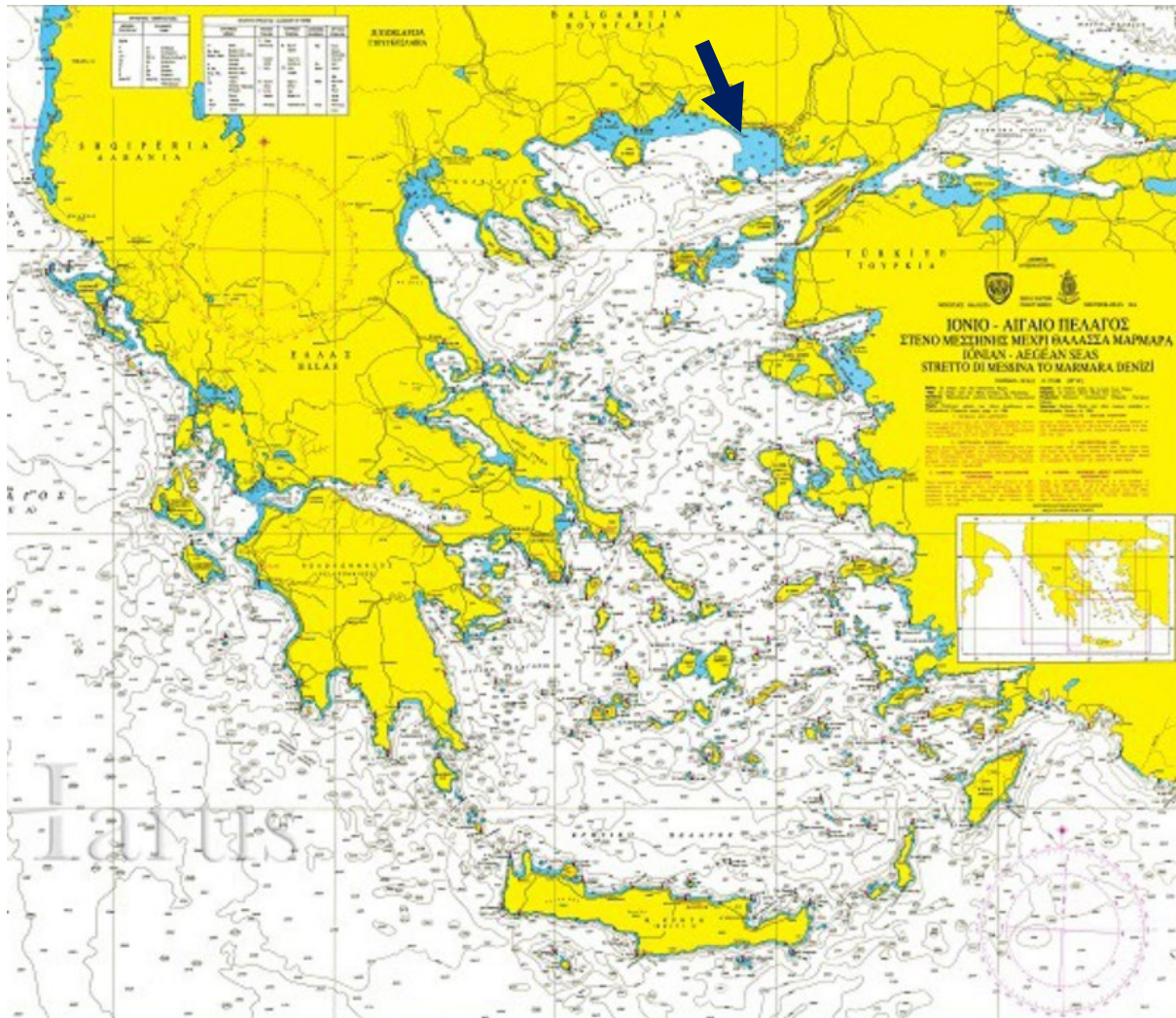

Figure 1 FSRU Location

The approx. water depth is 40m.

**Terminal Anchorage waypoint is located at co-ordinates: 40.76 N, 25.71 E**

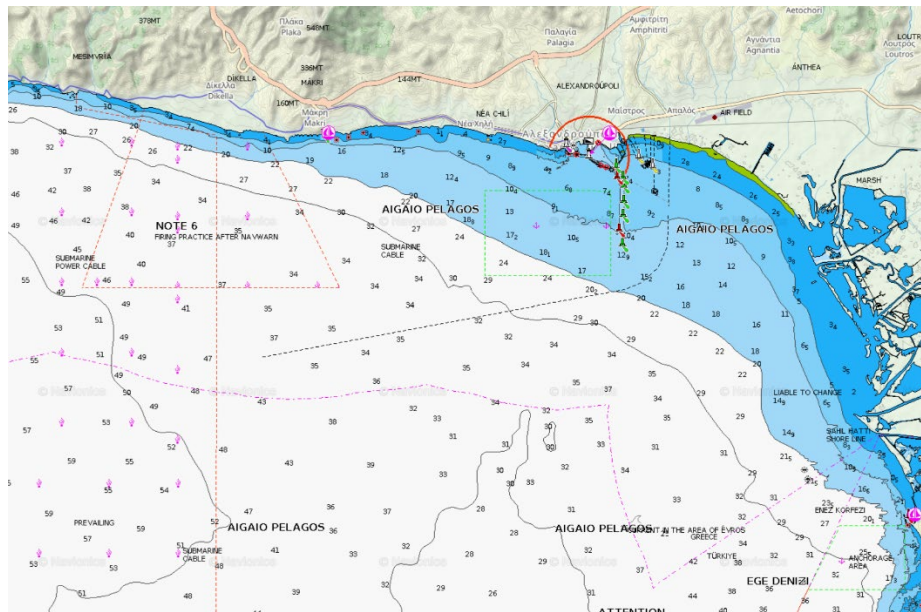

Figure 2 Close up Location

The ALEXANDROUPOLIS is orientated on a heading of 205 N (SSW) and held in position by a restricted catenary mooring (RCM) system, or spread mooring system, where four set of three mooring lines are deployed as shown in the following photographs.

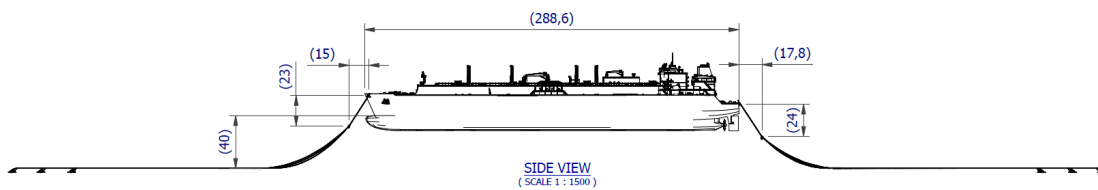

Figure 3 Anchoring Plan - Side View

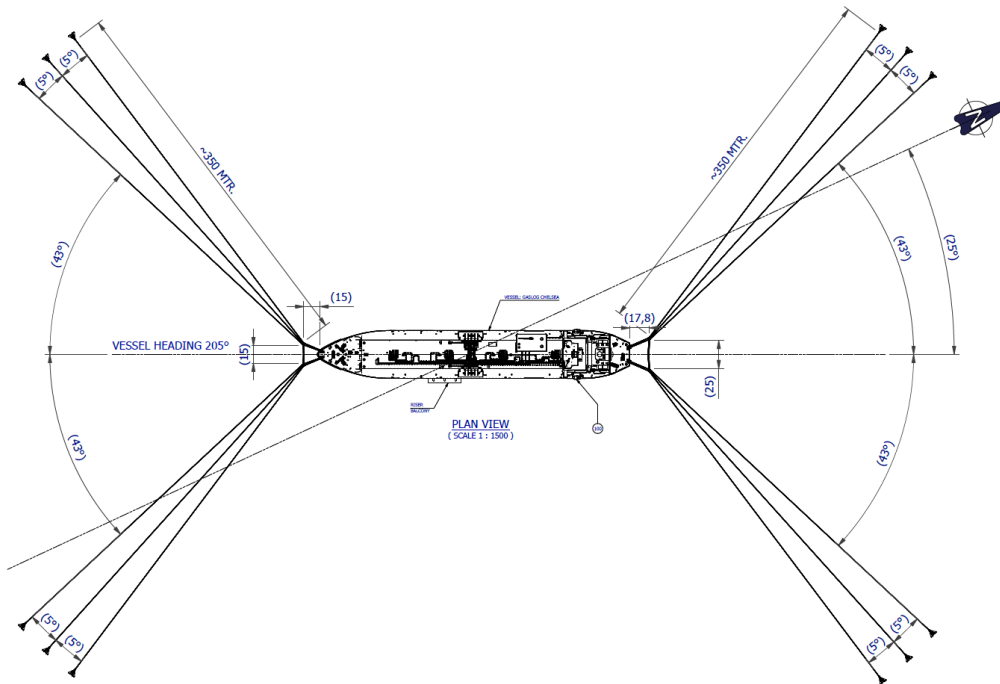

Figure 4 Anchoring Plan - Plan View

### 2.2.2. Exclusion Zone

The exclusion zone expands 500m outside the (blue) circular area including the mooring lines of the spread mooring and the FSRU (cyan circular area).

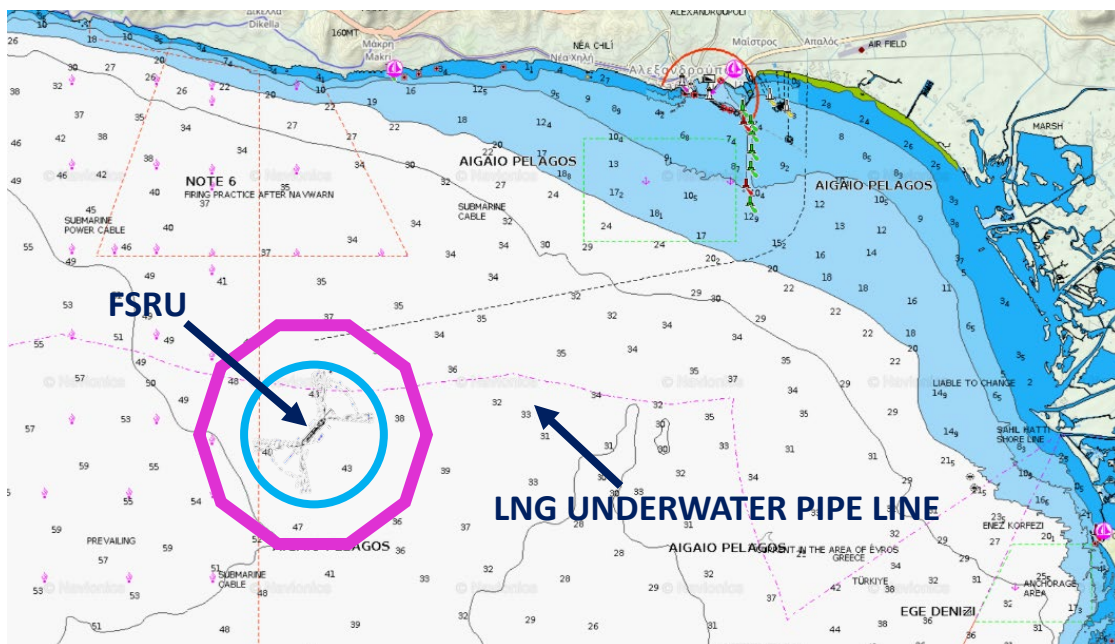

Figure 5 Exclusion Zone in Schematics (not in scale)

### 2.2.3. Restricted areas and Security Zones

Access to the Restricted Area is exclusively for LNG Vessels calling at the FSRU Terminal, mooring and service support vessels, either working for or authorized by the FSRU Terminal and Local Authorities, as well as those vessels associated with law enforcement agencies.

The FRSU Terminal operates at Security Level 1, however all security related questions should be addressed to the FRSU Terminal Representative and/or FSRU Master.

During interface, the Port Facility Security Plan within the exclusion zone applies. Any Security incidents on the LNG/C should be reported to the Port Facility Security and to FSRU security Officer with all ISPS Code related items in accordance with FSRU ALEXANDROUPOLIS ISPS manual requirements.

### 2.2.4. Time

FRSU ALEXANDROUPOLIS operates at Greece Time, EET (Eastern European Time).

**Summer time:** UTC/GMT +3 hours

**Winter Time:** UTC/GMT +2 hours

#### 2.2.4.1. Weather Forecast

GAS TRADE S.A. will provide weather forecasts as received from a meteorological service provider. The weather forecasts are by their nature only indicative of conditions that may be experienced. The STS Superintendent continuously advises this weather station located at main control room for his/her decision to continue, postpone and/or cease all the operations, in case of adverse weather.

Neither GAS TRADE S.A. nor the FSRU Terminal accepts any liability or responsibility whatsoever for the accuracy or otherwise of any weather forecast made available by the FSRU Terminal.

### 2.2.5. Weather Limitations

The following Table 1 and Table 2 present the generic weather limitations for the LNGC and the transfer operation.

Environmental limits prior to Berthing	
Criteria {any of the following}	Actions
<ul style="list-style-type: none"> <li>• &gt;25 Knots Mean Wind Speed*</li> <li>• &gt; 2.0m Significant Wave Height</li> <li>• &gt; 2 knots of current</li> <li>• &gt; 2° Pitch or Rolling of LNGC</li> <li>• &lt; 600m or (LNGC LOA x2) m Visibility whatever is shorter.</li> </ul> <p><small>*Forecast &gt;25 knots Mean Wind Speed for a duration of &gt; 3 hours</small></p>	Postpone Berthing with continuous assessment

Table 1 environmental Limits prior to Berthing

Environmental limits during Cargo Operation	
Criteria	Actions
<ul style="list-style-type: none"> <li>• Forecast <math>\geq 25^*</math> Knots (13 m/s) Mean Wind Speed</li> </ul> <p><small>* Mean Wind Speed &gt; 25 Knots for a duration of &gt; 3 hours</small></p>	Consider <b>suspending cargo operations</b> followed by disconnection of Cargo Hoses with continuous assessment in consultation between LNGC Master, FSRU Master and STS Superintendent.
<ul style="list-style-type: none"> <li>• &gt;25* Knots (13 m/s) Mean Wind Speed or</li> <li>• &gt;2.0m Significant wave height or greater</li> </ul> <p><small>* Mean Wind Speed &gt; 25 Knots for a duration of &gt; 3 hours</small></p>	Consider <b>suspending cargo operations and/or cast off.</b> Continuous assessment of the direction of wind and wave, in consultation between LNGC Master, FSRU Master and STS Superintendent.
<ul style="list-style-type: none"> <li>• <math>\geq 25</math> Knots (15 m/s) Mean Wind Speed or</li> <li>• 2.5 Significant wave height or</li> <li>• Pitch or Rolling of LNGC</li> </ul>	Consider Stopping Cargo Transfer, Drain and Purge Cargo Hoses and Disconnect. <b>Consider Casting Off.</b>

Table 2 Environmental Limits during Cargo Operations

The weather limitations presented in this section serve as operational thresholds based on historical data, industry best practices and simulation output. These values are subject to adjustment based on



real-time environmental conditions and operational assessment. The final weather limitations will be determined and agreed in the Joint Plan of Operations (JPO) prepared for each specific operation. All operational stakeholders must refer to the approved JPO before commencing any Ship-to-Ship (STS) transfer.

Weather criteria and actions are subject to continuous assessment and Master's final decision and agreement. Also, in line with the conclusions of the Pilot Training and Familiarization Workshop following criteria with respect to environmental limits should be subject to continuous assessment by both Masters and STS Superintendent prior to and during the operation:

- In periods of slack current, the LNGC can safely approach, berth and depart the FSRU in conditions with NE or SE winds of up to 25 knots.
- With the currents flowing at up to 1 kn from either the SE or NW, the LNGC can safely approach, berth and depart the FSRU in wind speed of up to 20 kn from either the SE or NE;
- With the currents flowing at up to 1.5 kn towards the SE, the LNGC can safely approach, berth and depart the FSRU in wind speed of up to 20 knots from either the SE or NE;
- With currents flowing at up to 1.5 kn towards the SE, the LNGC can safely approach, berth, and depart the FSRU in winds of up to 20 knots from W.

Mooring thresholds for wave height to also take into account results as shown at the latest OCIMF Information Paper *"Mooring Load Analysis during Ship-to-Ship Transfer Operations, First Edition April 2022"* for LNGC to LNGC – AT Anchor Operations.

#### 2.2.6. Navigational Charts

The position of the terminal is recorded on the nautical charts and publications after the completion of its installation and related clearance by the Administrator/Manager and the Maritime Authority/Hellenic Coast Guard to the Hellenic Navy Hydrographic Service, as follows:

- Nautical Charts & Publications of the Hellenic Navy Hydrographic Service (HNHS): XEE-109, 2, 4, 41, 42, 43, 47, 32, 33, 322, 3221, 322/1
- Corresponding charts are also issued by the British Admiralty. Covering requirements from the above Agencies for electronic maps (ECDIS) as well.
- British Admiralty Nautical Chart 1086
- British Admiralty Nautical Chart 1636

#### 2.2.7. Metocean Conditions

A met ocean study has been conducted to support the design of the FSRU ALEXANDROUPOLIS development and associated pipeline in the Northern Aegean Sea.

Winds typically come from the northeast (15-75°) in this region and can reach strengths greater than 20m/s from this direction as well as from the south. Winds are noticeably stronger in the winter months (Dec – Feb) compared to the summer (Jun-Aug). Overall, hourly mean wind speeds at 10m ASL are below 10m/s approximately 87% of the time.

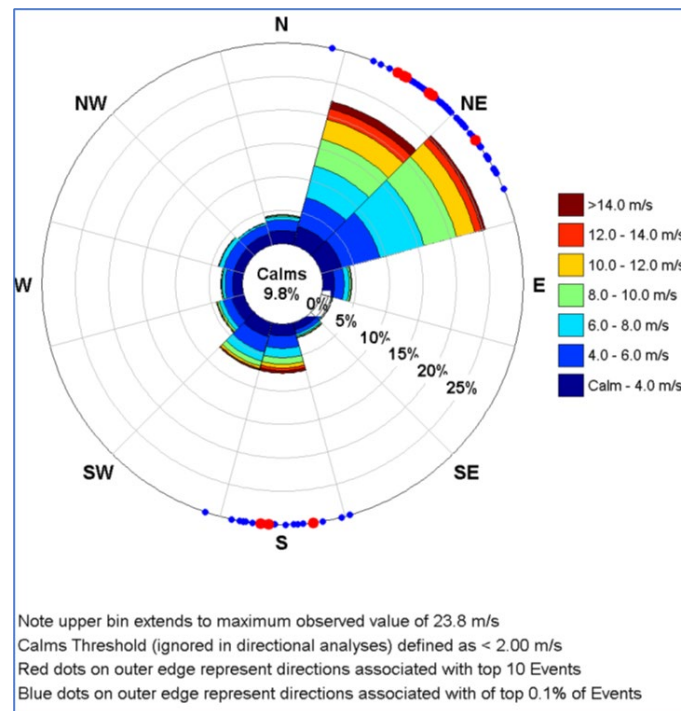

Figure 6 Wind Rose at 10m for the FSRU

Similar to the winds, the prevailing wave direction is from the east-northeast (45-105°). However, due to the limited fetch the waves do not exceed 1.75m in height from this sector. From the south, there is a certain amount of wave sheltering from the outer islands, but still there are pathways for transmission of offshore wave energy. Waves from the south can exceed 4m. Overall, waves are below Hs 1.5m approximately 97% of the time.

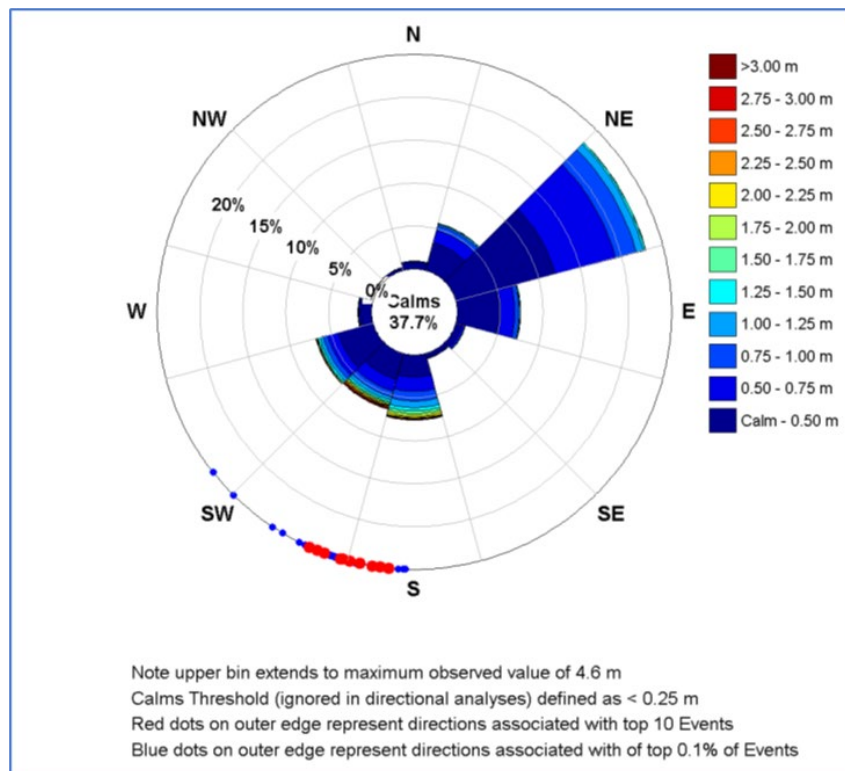

Figure 7 Wave Rose for the FSRU

Prevailing near-surface currents occur in either of two predominant directions, towards the SE and to the W. The ESE currents are associated with the regionally significant Samothráki Plateau anticyclonic gyre, which occurs most frequently and strongly during the spring and summer periods. Westerly currents are generally associated with the local wind forcing and are therefore most apparent near the surface. Surface currents are below 1.1m/s approximately 99% of the time.

The northern Aegean Sea water column is influenced by relatively low salinity inflows from the Black Sea and river catchments. The resulting water column stratification can have a strong influence on wind-induced current profiles. There is evidence in the model hindcast of the potential for extreme flow conditions driven by wind-induced baroclinic instabilities (internal waves). Due to these complex interactions the modelled current speed statistical distribution has a 'long tail', with rare (extreme) events exhibiting much higher magnitudes than the prevailing conditions.

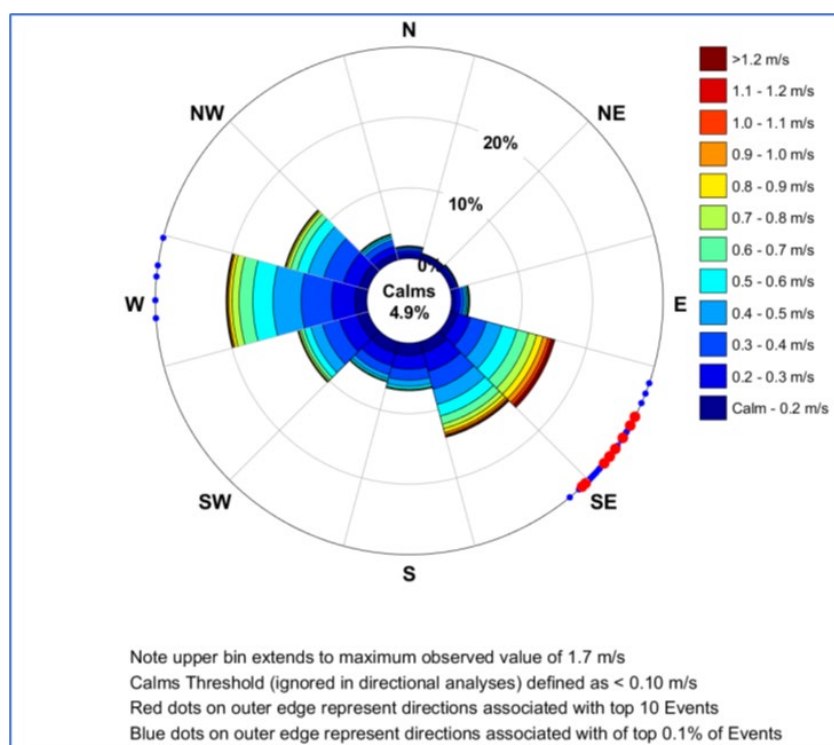

Figure 8 Near-Surface current rose for the FSRU

### 2.2.8. Location Assessment

Weather data have been examined for the duration of the last 5 years (Starting January 1<sup>st</sup>, 2019, to January 8<sup>th</sup>, 2024). Details charts for the below Weather Data can be found at section 2.2.6 of this report.

#### FSRU Offshore Alexandroupolis

The most important observations regarding the weather characteristics at Offshore Alexandroupolis can be found below.

- Wave Height** The most frequent Wave Height was up to 0,4m and rarely exceeded waves of more than 1,6m.
- Wave Period** Wave period was usually around 1,2s to 3,6s.
- Wave Direction** Wave Direction was calculated to be from 0 to 225 degrees meaning North to Southwest.
- Swell Height** The most frequent Swell Height was calculated between 0,2m and 0,4m. In very rare cases values exceed 0,8m.
- Swell Period** Swell Period was frequently between 1,2s to 6,0s. In a few cases reached and did not exceed the 11,0s. while the average was around 3,0s.
- Swell Direction** Swell direction was also calculated to be from the Northeast to Southwest.
- Wind Speed** Average Wind Speed was only around 7,8 knots and rarely exceeded 16,0 knots.
- Wind Direction** Wind Direction was also calculated to be mainly from the North - Northeast side and in a few cases from the Southwest.

## Summary

Weather conditions are generally suitable for STS operations. Offshore Alexandroupolis is an area that is mostly affected by Waves and Swell. The effect of Wind is relatively small (7,8 knots) as the wind speed rarely exceeds 16,0 knots. Attention is drawn with respect to the swell period, usually more than 11s and only when combined with a swell height of more than 1m which could present a challenge in vessels of smaller size. However, the same is subject to on-site assessment. Swell, Wave and Wind Direction are consistently from the Northeast while Wind Direction is also frequent from the West.

The complete Location Assessment, in line with Industry Guidelines (ICS/SIGTTO/OCIMF/CDI, 2013) and Service Provider Self-Assessment checklist (Oil Companies International Marine Forum, 2020), is available at the Location Assessment – Offshore Alexandroupolis report.

### 2.3. General Communications

<b>Maritime Authority / Coast Guard</b>
ALEXANDROUPOLI – Central Maritime Authority / Coast Guard
Address: EMPORIOU 7 - ARKADIOUPOLEOS
Postal Code: 68100
Phone: +302551356200
Email: alexandroupoli@hcg.gr

<b>Hellenic Joint Rescue Coordination Centre (JRCC)</b>
Address: Akti Vasiliadi, Gate E2
Postal Code: 18510
Phone: +30210-4112500, +30210-4101116-9, +30210-4220772, +302131371126, +302131371325
Email: jrccpgr@hcg.gr

<b>Greek Mission Control Centre (GRMCC)</b>
Address: Akti Vasiliadi, Gate E2
Postal Code: 18510
Phone: +302131371627, +30210 4082621 - 622 - 688, +30210 4633067 - 463, +30210 4177621, +30210 4175771

<b>ERC CONTACT DETAILS</b>	
Location	GR Emergency Response Room DIMITRA BUILDING 69 Akti Miaouli, 185 37 Piraeus, Greece
Telephone Numbers Hot Line (24HRS)	+30210 45 91 111
Telephone Numbers Upon ERC manning	Main Switch Board: +30210 459 1000 Emergency Response Centre (ERC): +30210 459 1280 +30210 459 1281

	ERC- BackUp Line: +30210 4283552
Fax Numbers	FAX to Email: +30211 268 7075 ERC on direct line desktop fax: +30210 428 3538
E-mail	General: <a href="mailto:lng@gaslogserv.com">lng@gaslogserv.com</a> ERC: <a href="mailto:emergencyresponse@gaslogltd.com">emergencyresponse@gaslogltd.com</a>
<b>FSRU MANAGER for GASTRADE SA</b>	
Contact email:	<a href="mailto:c.tsoumaris@gastrade.gr">c.tsoumaris@gastrade.gr</a>
Contact Tel:	+302104444200 ext:4217

Table 3 Terminal Contact Details

## 2.4. Terminal Policies

### 2.4.1. Drug and Alcohol Policy

The Company’s policy is that no officer, crew member, contractor or shore-based representative on any vessel that the Company manages or operates, will navigate the vessel, operate its onboard equipment or conduct business onboard, whilst under the influence of drugs or alcohol.

The Company has implemented a “zero tolerance policy” in the use and/or trafficking of internationally controlled substances and alcohol abuse, for both shipboard and shore-based personnel.

All shipboard and shore-based personnel are required to be in a condition to respond, at any time, to an emergency situation, while on duty. The misuse of legitimate drugs or the use, possession, distribution and/or sale of illicit or unprescribed drugs onboard or ashore, is strictly prohibited. Any use of a controlled substance which causes or contributes to unacceptable job performance or unusual job behaviour, is also prohibited.

A person is considered under the influence of alcohol and his/her performance impaired, when he/she has a blood alcohol content of 40mg/100ml, or greater. The Company requires a period of abstinence from alcohol to be exercised prior to any scheduled watchkeeping du-ties or work periods, as per Company Drugs and Alcohol procedures.

All sea-going personnel, onboard contractors and shore-based personnel shall sign a declaration of acceptance of the Company’s drug and alcohol policy. All sea-going personnel employed by the Company must undergo a drugs and alcohol screening test and pass it, before signing on.

Random and unannounced testing for use of banned substances and misuse of alcohol is regularly performed onboard all Company managed vessels, to monitor compliance with this policy.

If it is determined that a Company employee, onboard or ashore, has or is abusing controlled substances or alcohol, his/her employment will be terminated.

## 2.5. Berth Approval Parameters

The FSRU Terminal is designed in compliance with International Standards to provide a berth for any LNGC that successfully satisfies the Berth Approval Parameters and limitations. Any deviations from below figures will be examined on a case-by-case basis and risk assessment.

Maximum Capacity	About 180000 m <sup>3</sup>
Minimum Capacity	About 3000 m <sup>3</sup>

*Table 4 Berth Approval Parameters*

**Note 1:** All LNG Vessels must be capable of conducting LNG cargo loading and ballast operations simultaneously so as to minimize the area of the LNG Vessel exposed to wind while moored.

**Note 2:** For vessels exceeding the limitations as established above, a case-by-case analysis will have to take place and will be subject to the output of the assessment.

## 2.6. Fenders

The Fendering system can absorb energy for LNG Barges and LNGC up to 180k size.

Vessel should berth as parallel as possible with the FSRU parallel body contacting the fenders simultaneously.



*Figure 9 Primary Fender Positioning*

**Primary Fenders:** The FSRU has four (4) Jumbo TRELLEBORG Pneumatic Fenders 4,5-meter diameter and 9.0 meter long, wrapped in a tire net (4.922m with tire net). Fender internal pressure is 50kPa.

The primary fenders will be rigged on the Starboard side (as per Fender Mooring Arrangement Plan APPENDIX 7) in such a way that the smallest parallel body of which ever vessel FSRU or LNGC is covered

throughout the transfer operation considering the change in draft of both vessels. Secondary fenders will be suspended on the starboard side and at the fore/aft limits of the parallel body.

Secondary Fenders: The FSRU has two (2) Baby Pneumatic Fenders 2,0-meter diameter and 3.0 meter long, wrapped in a tire net (2.343m with tire net). Fender internal pressure is 50kPa.

Between operation fenders will always remain secured alongside to the FSRU depending on weather conditions.

All fenders are ISO 17357 compliant.

The above fender arrangement is based on typical mooring configurations. The Compatibility Study shall review the fender configuration and determine if different number and/or re-alignment is necessary or acceptable.

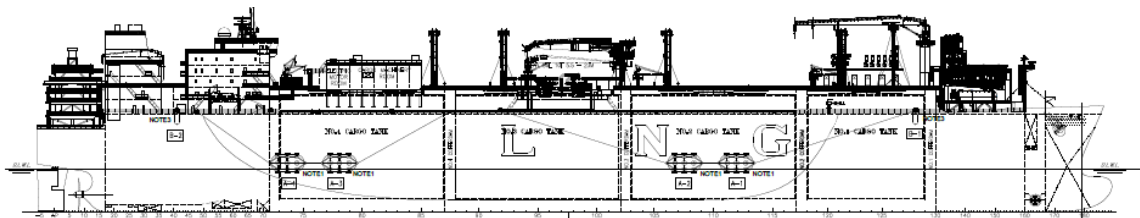

Figure 7 Primary fender position for receiving large LNGCs (145K-180K)

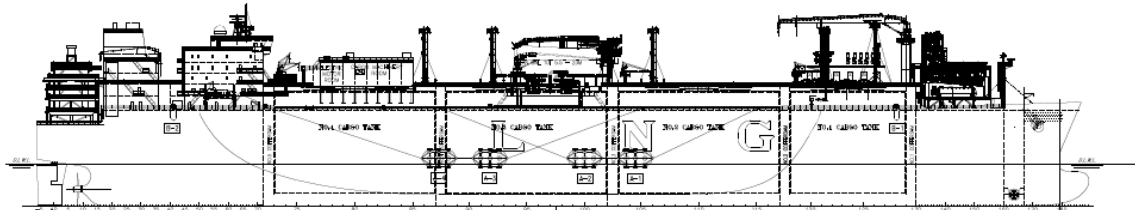

Figure 8 Primary fender position for receiving small LNGCs (3K-20K)

Appendix 4 includes details of the certificates of fenders.



## 2.7. Hoses

Multi-LNG White STS Composite Hoses are specially designed for Ship-to-Ship Operations where LNG at a temperature of  $-164^{\circ}\text{C}$  will be transhipped. Multi-LNG White hoses are also suitable for vapour return.

Hoses are 10" diameter and 18m long with ANSI 150lb raised face floating flanges each end.

Maximum flow rate through each hose is 2250m<sup>3</sup>/hr.

Hydrostatic test is conducted on the cryogenic hoses each year. The test must be conducted by either the manufacturer or a third party which is trained in hydrostatic testing to the following standards: ISO 1402:2009, NPR 5527. Once testing has been completed a test certificate should be made available for the FSRU and LNGC.



Figure 9 Gutteling Multi-LNG White Hose

A hose is connected to the female end of the ERC with the use of an electrical insulation gasket set. The opposite end of the hose which will be passed to the visiting LNGC is connected to a manual quick connect disconnect unit known as a “Cryo FC”.

Appendix 5 includes details of the certificates of hoses.



*Figure 10 Flexible Hoses during Cargo Operation*

# 3. Approval Procedures for LNGCs

## 3.1. Exchange of Information – LNGC to FSRU Terminal

Whenever possible, the following information should be sent:

- LNGC's name, sign, and IMO Number
- Vessel Description and dimensions
- Arrival Draught
- Manifold details
- Information as shown in other sections of this document.

## 3.2. Exchange of Information – FSRU Terminal to LNGC

The FSRU Terminal should ensure that the LNGC is provided with the facility's Marine Operation Manual and advise the Carrier of any defects to the terminal equipment.

The mooring plan and communications during mooring should be specified. Both Masters should review and agree on the final plans as presented by the STS Organiser and the STS Superintendent. The information will be shared through the Joint Plan of Operation and should include the below:

- General Description
- Berth Information
- Plan for approaching the berth, environmental limits and approaching speed.
- Characteristics and number of tugs, mooring boats and other external facilities.
- Personnel Transfer Arrangements
- Emergency Procedures
- Information contained in the Joint Plan of Operations as referenced in Section 4.2.

## 3.3. Vessel Approval Procedures

All other LNGCs calling at the FSRU Terminal before being accepted by GAS TRADE S.A. must be in compliance with:

- International Standards (i.e. within the International Association of Classification Societies (IACS))
- Conventions, rules, guidelines, and regulations laid down by the International Maritime Organization (IMO).
- The Oil Companies International Marine Forum (OCIMF).
- International Group of Liquefied Natural Gas Importers (GIIGNL).

- Society of International Gas Vessels and FSRU Terminals (SIGTTO) (or any successor body of the same).
- Any other internationally recognized agency or organization with whose standards and practices it is customary for international operators of such vessels to comply, including holding a valid operational OCIMF Ship Inspection Reporting system (SIRE) certificate).

### 3.4. Statutory and Regulatory Compliance

Vessels calling at the Terminal must be maintained in compliance with applicable International Conventions and Classification Society requirements.

LNGC Master should be prepared to present valid certificates indicating compliance with statutory and class requirements. Vessels calling must comply with applicable TERMINAL ACCESS CODE (TAC) and the TERMINAL USER AGREEMENT (TUA).

In order to approve a vessel for loading/discharging at the FSRU Terminal, the following pre-study must be performed:

- Compatibility Assessment: SIGTTO format (SSCS Spreadsheet) confirmation list to be completed.
- Review of Vessel's drawings, certifications, and photographs
- Assessment of Dynamic Mooring Analysis
- Vetting Approval: Participating vessel vetting assessment.
- Past Vessel Performance feedback

### 3.5. Ship Compatibility

A full compatibility assessment should be available before the STS operation.

The purpose of the assessment is to:

- Confirm the suitability of the two vessels for the operation.
- Provide vessel with necessary information for the preparation before operation.
- Identify aspects that require special management.

Before vessels' first call to the FSRU, the user ensures that a Ship-to-Ship compatibility study (SSCS) according to general SIGTTO, Ship to Ship Transfer Guide and the FSRU specific requirements is in place. The user will submit by email to [compatibility@gastrade.gr](mailto:compatibility@gastrade.gr) all documentation mention in section 3.6 to the FSRU Manager. A confirmation receipt should be sent within 60 minutes. In case such confirmation is not sent please contact the FSRU Manager (Contact details shown in Table 3) to confirm that the documents have been well received.

Upon completion of the SSCS, a compatibility assessment study will be prepared along with the acceptance message and vessel approval certificate. All needed documents will be forwarded to the FSRU Manager.

The FSRU Manager or relevant compatibility subject matter expert shall upload these documents in the Port Info Database for current and future reference.

Upon completion of the Ship-to-Ship compatibility study, a pre-transfer meeting might be proposed between the FSRU Manager, or delegate, the LNGC operator and the FSRU shore terminal operator, as applicable.

Indicative topics for review are the following:

- General information of the FSRU and the LNGC vessel.
- STS transfer equipment, manifold arrangements, working range & compatibility.
- Fender and Flat body position.
- Mooring arrangements & mooring tension limitation.
- Cargo pumps specification and arrangement.
- Short distance pieces & drawing.
- Emergency shut-down system.
- Ship to Ship link systems & Communication.
- Operating limitations.
- Loading rate and vapor handling.
- Other related items as applicable

Subject to a successful compatibility study, and the outcome of the pretransfer meeting, the FSRU approves the candidate LNGC for discharging.

### 3.6. Screening and Confirmation List

The following flowchart outlines the procedure for clearance and compatibility assessment implemented by GAS TRADE S.A when nominating participating LNGCs. The process involves two steps beginning with the Screening Process and upon successful assessment, the Compatibility Assessment. The nomination process involves a thorough documentary evaluation of plans/drawings and trading certificates of the nominated LNGC to determine the vessel's suitability.

GAS TRADE S.A. decision whether to allow an LNGC to berth at the FSRU Terminal will depend upon the prevailing or forecasted sea and weather conditions, as well as the handling qualities of the LNGC. Should an LNGC be rejected or delayed by GAS TRADE S.A. for any reason, GAS TRADE S.A. will provide the LNGC's Master or the Ship's Agent written reasons for the rejection or delay.

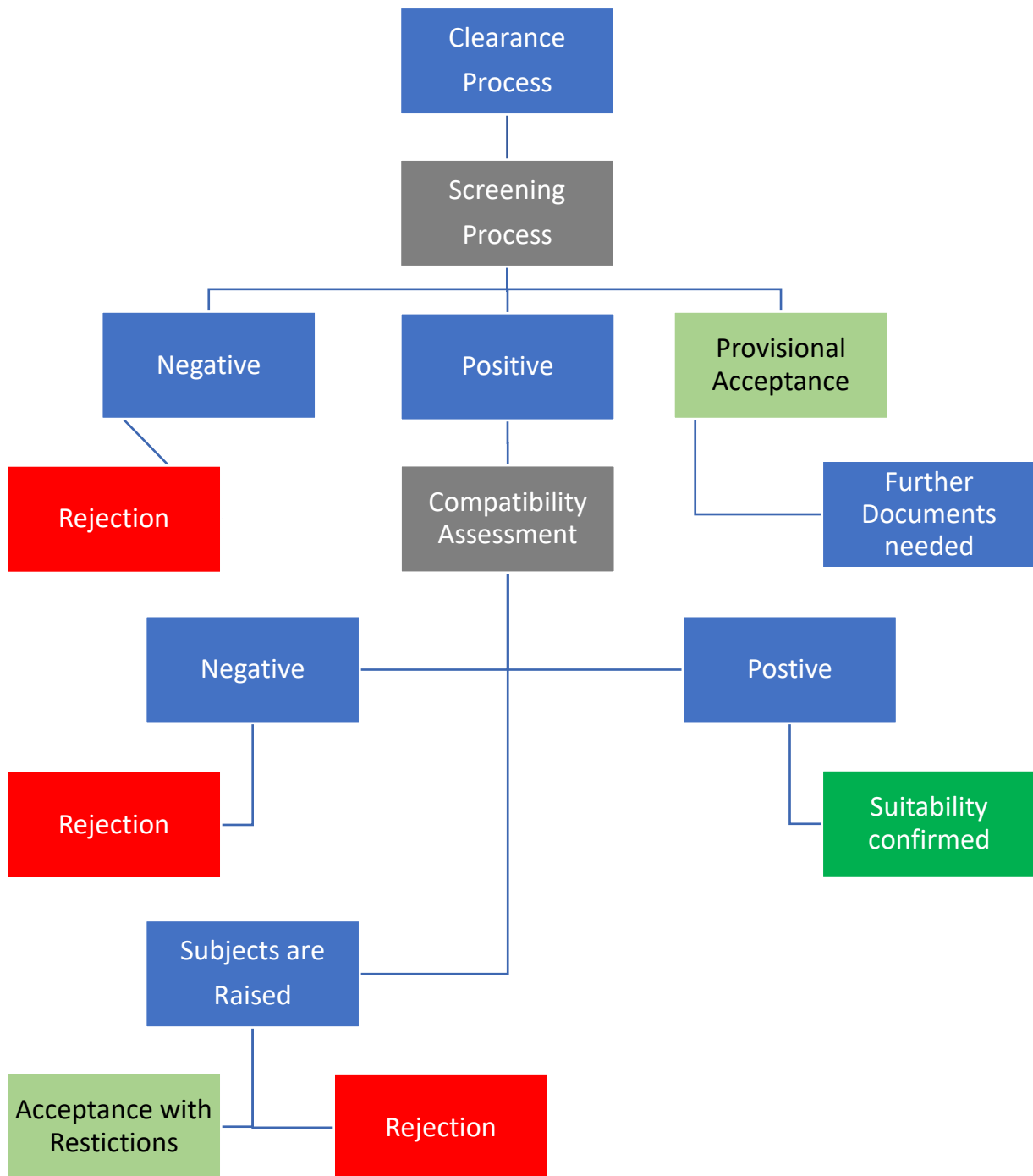

Figure 10 Screening Assessment Process

Below Table outlines the process of Suitability/ Compatibility Assessment in relation to the requested documents.

a/a	Process/Document
1	Vessel Description and/or Q88
2	SIGTTO Excel Worksheet information
3	Custody transfer monitoring system (CTMS) description and certification (temperature, tank level and volume)
4	Gas flow meter description and certification (if gas burned during transfer is available)
5	Ship's insurance documents (P&I Club and H&M coverage)
6	Certificate of Fitness
7	General Arrangement Plan
8	Mooring Arrangement Plan
9	Ship / shore interface plan (including manifold arrangement, manifold rail high/layout)
10	Trim and Stability booklet
11	VSL file for Optimoor study if available
12	Optimoor Study
13	International Ship Security Certificate
14	Class survey status report (Issued within the last 7 days)
15	Sister-Ship statement
16	Condition Assessment Program (CAP) certificate and report, if applicable
17	Latest Port State report
18	Date of latest SIRE report, observations and comments
19	Unloading/loading procedure including arm/hose draining standard procedure along with ramp up and ramp down procedure.
20	Draining and Purging procedures
21	Cooldown procedures of arms/hoses
22	Cargo tanks tables and cargo lines volumes.
23	Mooring procedure as per SMS (including berthing energy calculations)
24	Latest mooring inspection records and working hours of all mooring lines and tails
25	Reflex sheets or equivalent for emergency situations alongside and in port.
26	Muster list for emergency situations, ship and company organization chart to deal with these emergencies
27	Company policy regarding minimum manning in port
28	List of critical equipment's according to ISM code with relevant Risk Assessment
29	Company emergency contact list
30	Cooling down tank tables

a/a	Process/Document
31	Flange and SDP drawings
32	ESD system configuration along with ESD cause and effect diagram
33	Picture of manifold platform showing railing and manifold
34	Picture of personnel basket landing area
35	Vessel condition (e.g. ANKO in PDF file before and after operation)
36	Risk assessment for STS operation
37	Confirmation that the IGS System will be in full operational condition prior to and during the STS Operation

Table 5 Required documentation.

### 3.7. Vessel Approval Certificate

Following the clearance process, a certificate of approval or Clearance Certificate will be issued for each vessel. The validity period of the certificate will depend on the findings of the assessment. A vessel will be cleared/accepted for the FSRU ALEXANDROUPOLIS terminal throughout the duration of the Vessel Approval Certificate.

The onus is exclusively on the Master or Owner to ensure that the Vessel is seaworthy, and that all equipment is and remains in good working order and condition, including equipment required specifically for operations at the FSRU ALEXANDROUPOLIS terminal, subject that all re-assessment conditions, including initial approval conditions, are satisfied.

### 3.8. Dynamic Mooring Assessment Criteria

The following weather criteria need to be implemented for the dynamic mooring assessment. Results output should be forwarded to GASTRADE/ DYNAMARINE for review.

Case	Vessel combination	Winds knots/Dir*	Waves Hs (m) / Tz (s)/ Dir*	Swell Hs (m) / Tz)/Dir*
1	FSRU (B) Guest (L)	25kts/115	1.0m/ 5 sec / 160	0.35m / 5.0 sec /160
2	FSRU (B) Guest (L)	25kts/115	1.0m/ 5 sec /160	0.35m / 5.0 sec / 070
3	FSRU (B) Guest (L)	25kts/115	1.0m/ 5 sec/ 115	0.35m / 5.0 sec / 012
4	FSRU (L) Guest(B)	25kts/115	1.0m/ 5 sec / 160	0.35m / 5.0 sec /160
5	FSRU (L) Guest(B)	25kts/115	1.0m/ 5 sec /160	0.35m / 5.0 sec / 070
6	FSRU (L) Guest(B)	25kts/115	1.0m/ 5 sec/ 115	0.35m / 5.0 sec / 012

Table 6 Dynamic Mooring Assessment Criteria

\*Direction of wind and waves is TRUE and not relative to FSRU heading.



# 4. Preparation & Planning

## 4.1. STS Superintendent

The role of the STS Superintendent is not to relieve the Master(s) of their duties or responsibilities. The STS Superintendent should ensure, through the provision of professional advice and guidance to the Master(s), the co-ordination and safe completion of the STS operation.

It is recommended that the STS Superintendent:

- Reviews the location-specific risk assessment.
- Reviews the JPO and associated risk assessments.
- Verifies that agreed STS operating procedures are followed and that the operation is conducted in compliance with all applicable regulatory requirements.
- Confirms that all required reports are made to the appropriate authorities.
- Confirms that all relevant checklists are completed.
- Oversees the correct placement of primary and secondary fenders.
- Sights and reviews mooring equipment.
- Conducts a pre-operations discussion with the responsible persons of involved vessels, including lightering support vessel and tugs, as appropriate.
- Confirms that personnel involved in each part of the operation are properly briefed and understand their responsibilities.
- Discusses current and forecasted environmental conditions and the need for their continuous monitoring throughout the operation(s).
- For at sea transfers, discusses passage planning and agrees courses and speeds for manoeuvring and mooring operations.
- Verifies joint agreement of the mooring and unmooring plans.
- Reviews and verifies that any site-specific risk mitigations are in place.
- Supervises vessel approach and manoeuvring alongside.
- Confirms the safe connection of transfer hoses/arms and any associated emergency release systems (ERS).
- Verifies that any emergency shutdown system (ESD) is properly connected and tested.
- Confirms that cargo transfer rates are being monitored together with associated vapour management procedures.
- Verifies that the integrity of the mooring arrangement is being continuously monitored.
- Ensures that contingency plans are activated in the event of an emergency.
- Verifies that cargo transfer lines are properly drained and, where required, purged.
- Confirms safe disconnection of hoses/arms.
- Supervises the unmooring and the separation of vessels.

- Where applicable, supervises the return of primary and secondary fenders and transfer equipment.

The STS Superintendent should advise the Master when to suspend or terminate the STS operation.

In fulfilling the above role, in some locations the STS Superintendent may be supported by an STS Superintendent Assistant.

In addition, since the Pilots are not onboard the LNG vessel, any initiatives or advice for emergency cast-off or breakaway are delegated to the attending Lead Superintendent (STS Sup), in line with the provisions of latest (ICS/SIGTTO/OCIMF/CDI, 2013) Guidelines. Any decision will be taken by both vessels Masters in co-ordination with the STS Sup.

In case of planning of emergency breakaway, the STS Sup may take initiatives, as deemed appropriate, to:

- Notify for suspension of Cargo operations.
- Notify the tugs, by VHF or email @ (christos.pagidis@svitzer.com; fred.jeeninga@svitzer.com)
- Co-ordinate the toolbox meeting with all involved masters via VHF and receive agreement by FSRU and LNG Masters. Any emergency cast off plan needs to be clearly communicated with all parties.
- Co-ordinate tugs during cast-off as per plan.
- Advise both vessel Masters accordingly.

The responsibility always rests with both vessel Masters who both have the right of overriding authority.

#### 4.2. Joint Plan of Operations

Prior to commencement of any STS operation a joint plan of operation (JPO) should be developed to ensure that all parties involved, including the STS service provider, are in alignment with regard to how the operation is to be conducted.

In all cases the STS Superintendent or transfer organiser should establish agreement and consensus between all parties.

The JPO should include a compilation of information from various sources. For a particular location, a generic template may be used. Information may include the following:

- Details regarding rendezvous location and designated lightering area, including relevant risk assessment(s).
- Brief description regarding how the STS operation will be conducted, with respect to vessel approaching, depending on prevailing environmental conditions.
- Details regarding any local or government regulatory requirements and mandatory notifications.
- Communication protocols.
- Security requirements.

- Procedures associated with any personnel transfers.
- Details regarding any service craft and launches.
- Environmental operating parameters/limits for each stage of the STS operation. These should include environmental and operational limits that would trigger suspension of the transfer operation and disconnection and unmooring of the vessels.
- Fender configuration.
- Mooring plans and arrangements and sequence of running lines, including use of any specialist mooring equipment.
- Details of transfer and associated equipment, including the number, type and dimensions of cargo (and where applicable vapour) hoses and method of rigging/support.
- Maximum and minimum draught and freeboard anticipated during operations, including details of the stage of operations they relate to.
- Emergency procedures.
- Hose cooling down procedures.
- Pressure maintenance in the cargo containment and use of the GCU throughout the transfer operation
- Co-ordination of plans for cargo hose connection, draining, purging and disconnection, as appropriate.
- Detailed unmooring sequence.

JPO is included at Appendix 2 of this report.

#### 4.3. Toolbox meeting

Prior to the commencement of the STS operation, GASTRADE Co, or delegate will inform all involved parties for the date and place of the tool-box meeting lead by the STS Superintendent. The meeting will take place either physical, or remotely.

The contents of the meeting will include findings as identified during the planning process and will ensure that all parties are aware of the processes, hazards and applicable risk mitigation measures. Such topics of the toolbox meeting may include the following:

- General information of the FSRU and the LNGC vessel.
- JPO
- Applicable environmental and weather forecasting.
- STS Superintendent tasks, co-ordination and on-site interaction with both Masters
- Applicable Maritime Authority / Coast Guard Permissions
- STS transfer equipment, manifold and hose arrangements, working range & compatibility.
- Saddle transfer, positioning and adjustment.
- Fender and Flat body position during arrival and departure condition.
- Berthing energy & vessel approaching velocity.
- Mooring arrangements & mooring tension limitation.
- Equipment transfer after completion of mooring operations
- Personnel transfer compatibility.
- Emergency shut-down system settings
- Ship to Ship link systems & Communication.
- Ship – Ship emergency response procedures.
- Emergency cast-off procedures
- Emergency response communication.

- Ship shore safety checklist and safety tests procedure.
- Loading rate and vapor handling.
- Other related items as applicable

#### 4.4. Personnel Transfer Procedures

Normal Boarding Operations:

The FSRU terminal is fitted with a permanent boat landing platform on the Port Side and aft of the Riser's Porch. The boat landing platform is used for personnel transfer during normal operations of the terminal at the offshore site.

STS Operations:

The FSRU Terminal is fitted with an offshore Hose Handling Crane certified for personnel transfer. The crane is fitted to the starboard side of the FSRU terminal forward of the LNG manifold. The FSRU is fitted with a WAVE-4 device that will handle the transfer of personnel from the visiting vessel to the FSRU Terminal and vice versa.

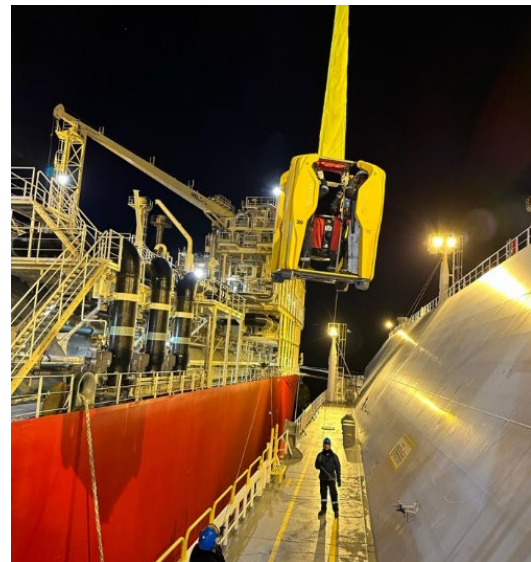

Figure 11 Personnel Transfer Basket

The FSRU crane operator shall be trained and certified for lifting personnel, in compliance with FSRU Management Safety Procedures. The FSRU shall appoint a Person in charge who shall manage the transfer operation and ensure that all personnel are briefed prior to boarding. The Person in charge cannot be the crane operator and cannot ride the WAVE device.



Figure 12 PTB Landing Area above the STBD Manifold

Prior the first Personnel Transfer on to the LNGC the Person in charge shall agree the safe landing area with the LNGC. The LNGC shall have at least one crew member available to tender the personnel transfer.

Personnel lifting operation shall commence after confirmation that the LNGC is securely moored – “All Fast” – following to the advice of the STS Superintendent and the permission by the FSRU Master or FSRU Chief Officer.

Personnel transfer shall comply with the safety weather limitations as per SMS Management System.

Personnel transfer shall comply with the safety weather limitations shown below:

Condition	Limitations
Wind Speed	20 knots
Visibility	Crane Operator should have a clear view of the pickup and set down areas
Vessel Motion	10-degree pitch and roll

*Table 7 Personnel Transfer - Weather Limitations*

#### 4.5. Hose Handling

Hose buns are required when moving the hoses. They are especially designed to allow for the safe lifting of the hoses. Used in conjunction with a crane, or other suitable lifting equipment, the hoses are lifted in a choker hitch position. Hoses must not be lifted by hand. Hoses must not be lifted with rope or slings as this will cause severe hose damage.

The handling of the cargo hose will be conducted using the FSRU crane which eliminates any movement between the Vessels.

The hoses will be lifted from the FSRU and manoeuvred close to the front edge of the corresponding saddle on the LNGC.

A large web strop, wrapped twice around the hose and chain block secured to the LNG manifold, will prevent the hose running over the saddle allowing it to bend towards the manifold.

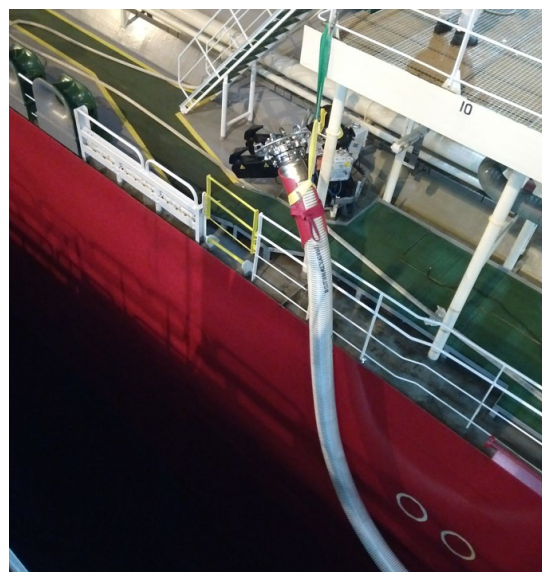

*Figure 13 Hose Lifting with hose buns*

The crane should be lowered slowly allowing the removal of the blanking flange from the Cryo FC. Once removed a new gasket will be installed and secured in place using the retention plate thumb screw of the Cryo FC.

The flange connector and hose will then be manoeuvred directly above the flange with a presentation angle of 25-30 degrees. The flange engagement plate must be set at the 12 o'clock position +/-30

degrees, with the clamp bolts in the fully open position. Carefully lower the flange connector ensuring that there is adequate clearance between the manifold flange and gasket, the position of which can be adjusted using the crane and slackening the chain block.

When the flange engagement plate is fully located the flange connector can continue to be lowered. The flange alignment plates will centralise the manifold flange. When the hose bun lifting strop becomes loose the flange connector will be fully located.

Once in location the clamps should be swung into position and tightened. It is recommended that 2 clamps are simultaneously tightened using a pair of torque wrenches in the advised sequence (1&2, 3&4, 5&6).

A pre-set torque of 100Nm should be applied at all clamp positions and then a final torque of 250Nm (for metal spiral wound gaskets). Once installed, the hose bun, strop and chain block should be removed from the hose.

#### 4.5.1. Saddles

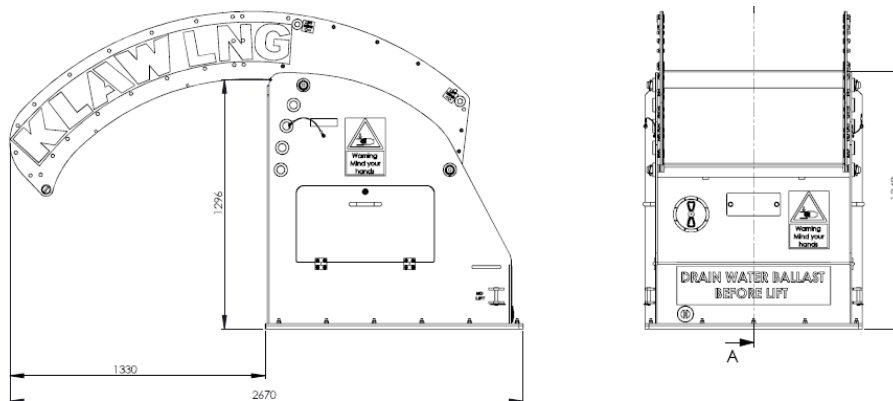

Figure 14 Saddles

KLAW LNG Adjustable Saddles are designed to support the weight of the cryogenic hoses, mitigating any bending and lateral stresses during an STS transfer. Additionally, the saddles protect and ensure correct connection and disconnection of the cryogenic hoses. The position of the saddles will be examined during the compatibility study, and FSRU, LNGC personnel will be informed before the arrival of the LNGC.

Double saddles are for use with the liquid and vapour lines which are used in connection with a Y-piece reducer, single saddles are used for single hose connection on the remaining liquid lines.



Figure 15 Double Saddles

The Fall Arrest System (FAS) equipment is located within the saddle. This is accessed through the hinged storage hatch.

Saddles without a FAS are provided for use on the LNGC.

The aluminium saddles support the transfer hoses when passing over the railing of the ship. They can be secured to the manifold platform via bolting arrangement or secured to the fishplate using anchors and ballast weight. The chute that the hose rests on can be adjusted to five different heights and so allowing STS transfer with a variety of ship configurations.

The PTFE lined hose chutes minimise friction and insulate against transfer of electrical charge from Vessel to Vessel.



Figure 16 Saddles transferred to LNGC

#### 4.5.2. Fall Arrest System

The FAS is mounted on the inside of the saddles located on the ALEXANDROUPOLIS. It is an adjustable, self-contained, hydraulic system with the purpose of controlling the speed at which the transfer hose descends between the two Vessels after disconnection in the event of an ESD2 activation.



Figure 17 Fall Arrest system on the FSRU

As the hose starts to descend the rope unwinds from the rope drum. This motion drives the hydraulic motor, which circulates hydraulic fluid through the hydraulic circuit and the flow control valve. The valves have been pre-set to ensure the correct speed of descent and

in an event of over-pressurisation relieves excess pressure to mitigate against a dangerous scenario.

The rope unwinds fully from the drum then unhooks safely and falls away and into the water. This process minimises the potential damage to the Vessels or the transfer system. If the hydraulic motor becomes jammed a slip clutch acts as a failsafe and ensures the drum continues to rotate at a safe speed.

# 5. Communications

## 5.1. General Communications

All interactions between the LNGC's crew, the STS Superintendent and FSRU Terminal must be conducted in English. If the Master of the LNGC is unable to comply, they must inform the STS Organiser and FSRU Terminal in advance, and a mutually acceptable solution should be reached.

General communications will be via VHF channel 17 with back up communications via ships UHF radio channel 1. A UHF radio along with a spare battery and battery charger is to be provided to the LNGC by the ALEXANDROUPOLIS once all fast.

Both Vessels engaged in STS operations shall maintain a continuous listening watch on VHF channels 12 and 16 during their stay at the ALEXANDROUPOLIS.

However, communications between LNGC and the FSRU Terminal are primarily carried out using a FSRU Terminal provided UHF radio. Alternatively, communication will be via VHF radio on a pre-agreed Channel. During the pre-transfer meeting communication between the two vessels will be tested.

Additionally, the following services can be found on these frequencies.

Channel	Frequency (MHz)	Description
06	156.300 - 156.300	Inter Ship Safety
08	156.400 - 156.400	Reserved for Pilots & Tugs
09	156.450 - 156.450	Reserved for Pilot
12	156.600 - 156.600	Port Operations
16	156.800 - 156.800	International Distress, Safety and Calling
-	450.3875 - 460.3875	Berthing Aid System

*Table 8 VHF/UHF Channels to be used*

## 5.2. Ship/Shore Link

The primary system utilized to establish a means of communication between the LNGC and the FSRU Terminal will be via either:

- Fibre optic link, or
- Copper cable (electrical) link.

Both connections will be installed and tested well in advance of the commencement of operations. Nevertheless, the fibre optic link will serve as the primary connection.

This includes communication for FSRU Terminal/LNGC and LNGC/FSRU Terminal Emergency Shut Down (ESD) signalling. The copper cable link will also transmit the same information but using a dedicated pair of wires for each signal.



The LNGC's crew will establish the fibre optic and electrical links before the hoses connection begins. These links will remain connected until the hoses are disengaged. Subsequent to the disconnection of either the fibre optic or electrical link, the LNGC should continue monitoring the agreed UHF or VHF channel, as established in the pre-operation meeting.

If there is a failure in the communication system providing the ESD/data link, all loading operations will be halted until the fibre optic and electrical link is restored.

### 5.3. Ship/Shore Safety Checklist

Before the commencement of the STS operation the relevant Ship/Shore Safety Checklist should be completed as per ISGOTT Guidelines. The relevant checklist should be traced at Appendix 3.

## 6. Arrival Procedures for LNGCs

### 6.1. LNGC Arrival Requirements

The vessel's crew shall perform pre-arrival checks that comply with the recommendations of SIGTTO. Records shall be maintained and made available to the Terminal and Port State Control when required. Confirmation of completion of pre-arrival checks and any deficiencies shall be reported at the pre-transfer or pre-arrival toolbox meeting. With respect to the LNGC Preparedness, the following arrival requirements should be considered:

<b>LNGC's tank pressure on arrival</b>	Shall not exceed 100 mbar(g) on arrival
<b>LNG Liquid temperature on arrival</b>	-158,5 deg C

#### 6.1.1. Discharging Arrangements Spool Pieces

The incoming LNGC will not be required to remove their SDP 16". Manifold filters are also to retain in place. Subject reducers 16" to 10" will be provided to LNGC to be connected to the vessel's spool piece. Cargo Hoses later on will be connected to the reducer 10".

### 6.2. Pre-Arrival Procedures – LNGC

Please complete and return the below mentioned forms as well. Please also coordinate with the relevant local Agent for the below required forms/documents.

1. International Tonnage Certificate.
2. Any Certificate showing MMSI of the vessel (Ship Station license or any other with the MMSI on it).
3. Classification Certificate.
4. Certificate of Registry.
5. International Ship Security Certificate (ISSC).
6. Safety Construction Certificate.
7. Safety Equipment Certificate + Supplement form E.
8. Safety Radio Certificate + Supplement form R.
9. International Load Line Certificate.
10. International Safety Management Certificate (SMC).
11. Document of Compliance (DOC).
12. International Oil Pollution Prevention Certificate + Supplement.
13. International Air Pollution Prevention Certificate+ Supplement (if applicable).
14. International Sewage Pollution Prevention Certificate.

15. Certificate of Insurance or Other Financial Security in Respect of Civil Liability For Bunker Oil Pollution Damage.
16. Certificate of Insurance or Other Financial Security in Respect of Civil Liability For Oil Pollution Damage. (if applicable).
17. Certificate of Fitness for dangerous chemicals in bulk (if applicable).
18. EU MRV Document of compliance (if available)
19. Inventory of Hazardous Material Certificate+ Supplement (if applicable).
20. Minimum Safe Manning Certificate.
21. P&I Entry Certificate.
22. Continuous Synopsis Record.
23. International Ballast Water Management Certificate.
24. MLC certificate.
25. Maritime declaration Of Health. – To be submitted at 72 hours prior arrival, resubmitted every day until vessel's departure (with stamp and signature).
26. List of the 10 last ports of call with dates of arrival and departure.
27. IMO Crew List in EXCELL format. (Only the passport number should be mentioned, not the seaman book nbr).
28. New Safe Sea Net (nmsw) file – (\*Fill in instructions as follows).
29. Form A2.
30. Form A3.
31. ISPS FORM.
32. Waste Declaration form.
33. Ship's stores declaration with stamp and signature in color.
34. Electronic list with stamp and signature in color.
35. IMO declaration with stamp and signature in color.
36. Crew effects declaration.
37. Narcotic list with stamp and signature in color.
38. Last date and place of delivery for sludges, bilges and garbage.
39. ETA update 96/72/48/24 hrs
40. Scanned copies of all crew passports in color.
41. Crew list with stamp and signature in color.
42. Copy of last seven days report of oil record book and copy of the last delivery receipt of waste oils.
43. Copy of last seven days report of garbage record book and copy of the last delivery receipt of garbage.
44. Certificate of Competency + Endorsement + Flag Endorsement + SSO or Security Awareness of the All the crew that are mentioned in the minimum Safe manning + GMDSS Certificates + endorsements + flag endorsements.
45. Condition of Use

For instructions on how to submit and complete the required questionnaires/files, please contact and coordinate with the local agent.

### 6.3. Notification to Authorities

The following documents should be timely prepared by GASTRADE, for submission to the authorities for clearance purpose.

1. Valid Fender Maintenance Certificates
2. Valid Hose Maintenance Certificates

3. (ICS/SIGTTO/OCIMF/CDI, 2013) and other applicable Checklists
4. Title and contact details of the STS Organiser
5. Details of the STS Superintendent
6. Confirmation that both vessels inert gas systems are in full operational condition.
7. Joint Plan and Risk Assessment of the Operation

#### 6.4. Pre- Arrival Communication

The following notices will have to be sent to communication recipients according to mailing list shown at section 6.6.1

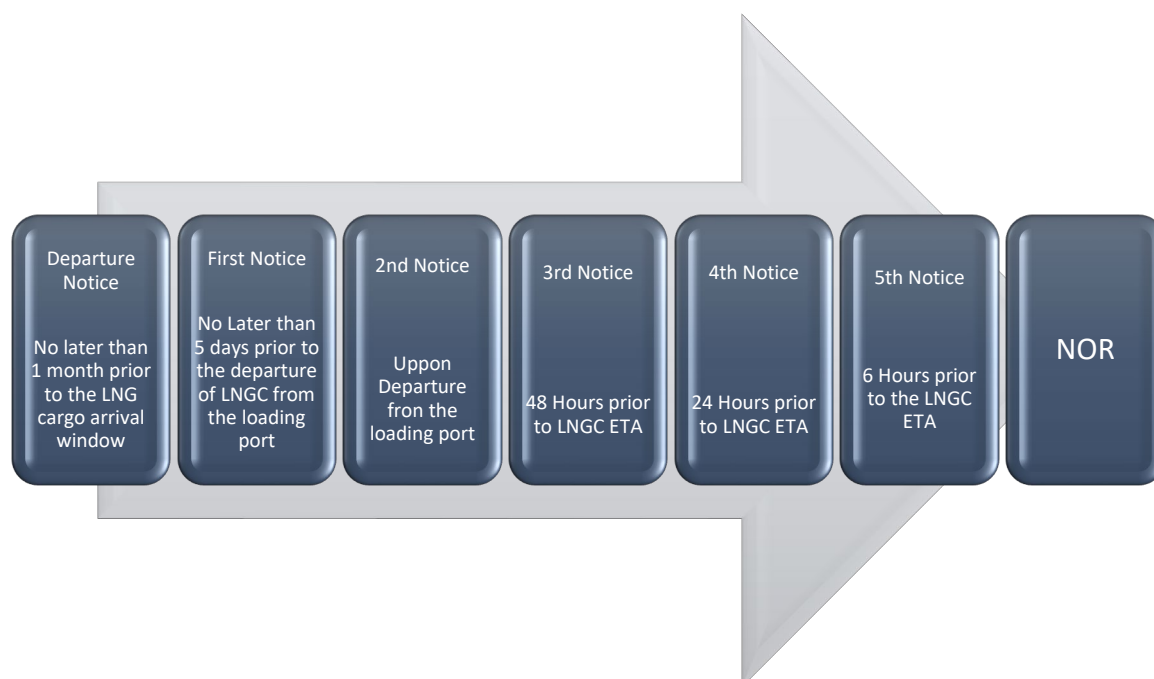

##### 6.4.1. Departure Notice

No later than one (1) month prior to the LNG Cargo Arrival Window the User shall inform Gastrade S.A. any information relating to the delivery of the LNG Cargo if different from the information in the Delivery Programme.

If, after issuing the Departure Notice, the User anticipates a change, by way of either increase or decrease, of more than the Allowable Volume Tolerance measured in m<sup>3</sup>, which is plus or minus 2%, in the LNG Cargo Volume, or of more than the Allowable Energy Tolerance as measured in kWh, which is plus or minus 2%, in the LNG Cargo Energy Content for a particular LNG Cargo, the User shall promptly provide notice thereof to GASTRADE S.A and include in such notice User's new estimate of the LNG Cargo Volume or LNG Cargo Energy Content

##### 6.4.2. First Notice

A first notice (the "First Notice") which shall be sent five (5) days before the departure of the LNG Vessel from the Loading Port and which shall set forth the time and date that loading is expected, the

quantity (expressed in kWh) and the volume (expressed in cubic metres) of LNG expected to be loaded on board FSRU, the ETA, and any operational deficiencies in the LNGC that may affect its performance at the Terminal or berth and the characteristics of the LNG comprising the LNG Cargo as determined at the time of loading.

Such notice shall include the following:

- A) Vessel Name & IMO Number
- B) Gross LNG cargo capacity of the nominated LNG vessel
- C) Name of the loading port and the scheduled departure date from such loading port
- D) Estimated Time of Arrival ETA
- E) Expected quantity (expressed in kWh) and volume (expressed in Cubic Meters M<sup>3</sup> of LNG and specification of the LNG to be unloaded
- F) Estimated saturated pressure and temperature of the LNG to be unloaded.

#### 6.4.3. Second notice

A second Notice (the “**Second Notice**”) which shall be sent upon the departure of the LNGC from the Loading Port and which shall set forth any changes to the ETA and the quantity (expressed in kWh) and the volume (expressed in cubic metres) of LNG loaded on board the LNGC as measured at the time of loading.

Such notice shall indicate the following:

- A) The information in respect of such Confirmed Cargo contained in the notice set out in above (as may have been subsequently updated) together with any changes thereto,
- B) The planned LNG Heel quantity to be left on board after the LNG Vessel completes unloading,
- C) Any operational deficiencies in the LNG Vessel
- D) Any additional information that the Contractor reasonably requests and shall be submitted in line with the form included in the Commercial and Operations Manual as prepared by the Contractor;

#### 6.4.4. Third Notice

A third Notice (the “**Third Notice**”) to be sent forty-eight (48) hours prior to the ETA set forth in the First Notice confirming or amending such ETA.

Such notice shall indicate the following:

- A) Expected time & date that the loading was completed
- B) Volume, expressed in cubic metres, of LNG loaded on board the FSRU
- C) Average cargo temperature and pressure (in millibars) of each cargo tank.

Confirmation that the following have been tested and/or are fully operational:

1. Navigation, mooring, safety & engine systems
2. Cargo system & boil off control systems
3. Gas detection systems
4. ESD system, alarms, and interlocks
5. Cargo tank high- and low-level alarms
6. High- & Low-Pressure alarms
7. Remotely operated valves
8. FF – Cargo tanks/lines are free of oxygen.
9. GG – No tank leakage
10. HH – Marine Security Level

If thereafter such ETA deviates more than three (3) hours from that advised in the Third notice, then the Vessel Master must promptly advise the Terminal Operator of the corrected ETA.

#### 6.4.5. Forth Notice

A fourth Notice (the “Fourth Notice”) to be sent twenty-four (24) hours prior to the ETA set forth in the Second Notice confirming or amending such ETA.

Such Notice shall include the following:

- AA – Ship’s name & call sign
- BB – Confirming or amending ETA.
- CC – The average cargo temperature and pressure (in millibars) of each cargo tank.

If thereafter such ETA deviates more than one (1) hours from that advised in the Third Notice, then the Vessel Master must promptly advise the Terminal Operator of the corrected ETA.

#### 6.4.6. Fifth Notice

A fifth Notice (The “fifth Notice”) To be sent six (6) hours prior to the ETA set forth in the Third Notice confirming or amending such ETA.

Such Notice shall include the following

- AA – Ship’s name & call sign
- BB – Confirming or amending ETA.
- CC – Notice of Readiness
- DD – The average cargo temperature and pressure (in millibars) of each cargo tank.

If thereafter such ETA deviates more than one (1) hours from that advised in the Third notice, then the Vessel Master must promptly advise the Terminal Operator of the corrected ETA.

At the time of loading (the “Quality Notice”): (i) the gross calorific value; (ii) the molecular percentage of hydrocarbon components and nitrogen; (iii) the average temperature; (iv) the hydrogen sulphide, sulphur, water, carbon dioxide, mercury and total sulphur content; and (v) the presence of any foreign or objectionable materials. The Owner or its agent shall inform the Contractor as soon as reasonably practicable if the Owner is notified of any revision (as to molecular composition and gross calorific value of the LNG when loaded onto the LNG Vessel) of the information provided in the Quality Notice. The Quality Notice shall also attach the certificate of analysis, or the quality certificate issued by the cargo surveyor at the Loading Port.

### 6.5. Notice of Readiness (NOR)

Notice of readiness to discharge (the “Notice of Readiness”) when the LNG Vessel has arrived at the Pilot Boarding Station at or near the FSRU Site, is ready to proceed to berth at the FSRU Site and has received the necessary clearances and is otherwise in all respects ready to proceed to berth and unload a Duly Confirmed Cargo of LNG. Notice of Readiness shall be effective: (i) if the LNG Vessel arrives within the Arrival Window, when given; or (ii) if the LNG Vessel arrives outside the Arrival Window, at the earliest time.

The issuance of the Notice of Readiness for an LNGC is subject to:

Any applicable restrictions, including any night-time transit restrictions, imposed by Governmental Authorities or Pilots, or night-time berthing restrictions imposed pursuant to the TAC;

- (i) such LNGC has received all relevant port and security clearances (except those clearances which will be received after

A Notice of Readiness shall become effective as follows:

- (i) for an LNGC arriving at the Pilot Boarding Station at any time before 07:00 hours on the day of the LNG Cargo Arrival Window allocated to such LNGC, a Notice of Readiness shall be deemed effective at 07:00 hours on the day of the LNG Cargo Arrival Window; or
- (ii) for an LNGC arriving at the Pilot Boarding Station at any time during the LNG Cargo Arrival Window allocated to such LNGC, a Notice of Readiness shall become effective at the time of its issuance; or such LNGC leaves the Pilot Boarding Station pursuant to applicable port procedures);
- (iii) such LNGC is ready to proceed to berth;
- (iv) such LNGC is ready to transfer cargo.

A Notice of Readiness shall become effective as follows:

- (i) for an LNGC arriving at the Pilot Boarding Station at any time before 07:00 hours on the day of the LNG Cargo Arrival Window allocated to such LNGC, a Notice of Readiness shall be deemed effective at 07:00 hours on the day of the LNG Cargo Arrival Window; or

- (ii) for an LNGC arriving at the Pilot Boarding Station at any time during the LNG Cargo Arrival Window allocated to such LNGC, a Notice of Readiness shall become effective at the time of its issuance; or
- (iii) for an LNGC which was required to leave the berth for reasons that would have justified an extension to LNG Unloading Window and then returned to the berth, a Notice of Readiness shall become effective upon Terminal Operator's notice to the LNGC that it is ready to again receive the LNGC at the LNG unloading berth; The NOR tendered by the LNG Vessel's Master must:
  - Be Signed by the Master of the LNG Vessel.
  - State the time and date it was tendered; and
  - be addressed to the FSRU Master. In copy to the FSRU OIM Operator

Upon receipt of a valid NOR, the FSRU Master shall provide the LNGC with instructions for berthing at the Terminal.

## 6.6. Mailing List

### 6.6.1. For ETA reports

Kindly ensure that below emails are always in Copy (CC) during the issuance of ETA Reports:

- [CommercialOps@gastrade.gr](mailto:CommercialOps@gastrade.gr)
- [Operations@gastrade.gr](mailto:Operations@gastrade.gr)
- [i.lysaridis@gastrade.gr](mailto:i.lysaridis@gastrade.gr)
- [c.tsoumaris@gastrade.gr](mailto:c.tsoumaris@gastrade.gr)
- [axd.portservice@gastrade.gr](mailto:axd.portservice@gastrade.gr)
- [alx@gaslogserv.com](mailto:alx@gaslogserv.com)
- [vmillas@gaslogltd.com](mailto:vmillas@gaslogltd.com)
- [gsachpatzidis@gaslogltd.com](mailto:gsachpatzidis@gaslogltd.com)
- [info@dynamarine.com](mailto:info@dynamarine.com)
- [i.georgiou@gastrade.gr](mailto:i.georgiou@gastrade.gr)
- [i.karamanlis@gastrade.gr](mailto:i.karamanlis@gastrade.gr)
- [s.tsiantoulas@gastrade.gr](mailto:s.tsiantoulas@gastrade.gr)

### 6.6.2. For Compatibility Assessment

Kindly ensure that below emails are always in Copy (CC) for the compatibility assessment process:

- [info@dynamarine.com](mailto:info@dynamarine.com)
- [operations@gastrade.gr](mailto:operations@gastrade.gr)
- [c.tsoumaris@gastrade.gr](mailto:c.tsoumaris@gastrade.gr)
- [s.zacharis@gastrade.gr](mailto:s.zacharis@gastrade.gr)
- [gsachpatzidis@gaslogltd.com](mailto:gsachpatzidis@gaslogltd.com)
- [i.georgiou@gastrade.gr](mailto:i.georgiou@gastrade.gr)
- [i.karamanlis@gastrade.gr](mailto:i.karamanlis@gastrade.gr)



## 6.7. Pilotage

Pilot Services will be provided by the competent State Agency (Navigation Agency of the Ministry of Maritime Affairs and Insular Policy). The use of Pilots is compulsory for LNGC and LNG barge to be berthed to the FSRU. The available Pilot services is standby 24 hours per day. The request for a Pilot shall be done by the LNGC agent with at least 72 hours of ETA at the anchorage and 3 hours before the estimated time of unberthing from the FSRU. The Pilot communication will be monitored via VHF Channel.

The Pilot Boarding Station is at a distance of 3NM from the FSRU. Pilot as well as the STS Superintendent are advisor to the bridge team of the LNGC (or LNG Barge), while the Master remains in command and is responsible for the safe navigation.

Any abnormalities and defects to the following which impacts the visiting vessel to berth, unberth, remain alongside or navigate shall be reported to the Maritime Authority / Coast Guard and the FSRU O&M Operator.

- Mooring Systems
- Propulsion System
- Steering Gear
- Position Monitoring system

If the visiting vessel Master decides not to follow the Pilot Instructions, then the event including the reasons shall be reported immediately by her Master to the agent who shall forward this information to the FSRU O&M Operator and Maritime Authority / Coast Guard.

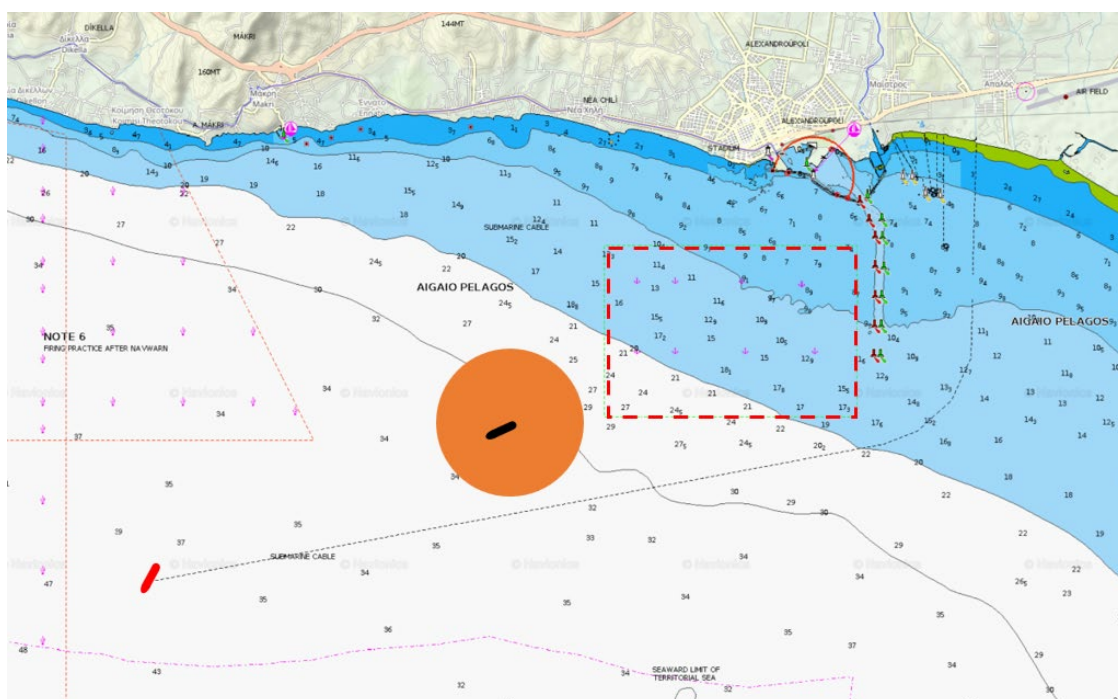

Figure 18 Pilot Boarding Area

### 6.7.1. Pilot boarding requirements

For safe boarding of pilots, the following points are stressed:

The rigging of pilot ladders, and the embarkation and disembarkation of pilots thereby, shall be supervised by a responsible officer of the LNGC.

Every pilot ladder shall be secured in a position clear of any possible discharges from the LNGC, and so that each step rests firmly against the LNGC's side.

- Every pilot ladder shall be secured in a position where the pilot can gain convenient access to the LNGC after climbing not less than two metres and not more than nine metres.

If the distance from the water to the access point of the LNGC exceeds nine meters, access from the pilot ladder to the LNGC must utilize an accommodation ladder or an equally safe and convenient alternative.

During nighttime, adequate lighting must be provided for the pilot ladder alongside the position where the pilot boards the LNGC. This illumination ensures visibility. Additionally, there should be a lifebuoy and a heaving line readily available at the ladder for safety purposes.

## 6.8. Tugs & Stand-by Tug

LNGCs are required to berth and un-berth with approved Tugs. These Tugs are also required to remain on standby in close proximity to the LNGC throughout its stay at the FSRU Terminal so as to:

- Keep a vigilant security watch.
- Remain accessible to promptly offer assistance in scenarios such as:
  - Early departure needs.
  - Emergency situations, which may involve providing firefighting support.

One (1) Standby Tug with Fire Fighting capabilities (Fire-fighting FiFi Class 1 notation) will patrol the Terminal on a 24/7 basis and while any vessel berthing. One (1) and pilot shall be assigned to escort the incoming vessel from the Pilot Boarding Station to the Terminal/ anchorage and vice versa.

A minimum of four (4) tugs is required for the berthing and unberthing operations. Any individual tug shall have a bollard pull (BP) of 80 tons.

The tugs are equipped with VHF for continuous communication between the incoming vessel and the Terminal. Tugs shall maintain a 24-hour listening watch at channel XYZ in case of emergency.

If during manoeuvring, there is a radio communication failure between the tugs and the vessel then the operation should be aborted.

During the STS transfer the visiting vessel shall conduct a communication check with the Standby Tug on an hourly basis and inform the FSRU Terminal for any communication failure. Official communication language between visiting vessel and tugs is English.

## 6.9. Berthing Approach Procedures

All manoeuvring of LNG Vessels proceeding to and within the Exclusion Zone must be conducted with appropriate care and caution at a speed and in a manner that must not endanger the safety of other

vessels or the FSRU Terminal. Manoeuvring procedures will be agreed and discussed with the appointed Pilot.

Each ship should take the following into account:

- All navigation and communications equipment should be in full working order and proficient helmsmen should be used.
- Engine movements and steering gear should be remotely controlled from the bridge.
- Courses and speeds requested by the manoeuvring ship should be followed by the constant heading ship. A common system for assessing speed should be agreed, such as speed through the water or over the ground.
- Where possible, the ship's speed should be controlled by adjusting engine revolutions or propeller pitch. This will facilitate fine adjustments, for example plus or minus 5 revolutions per minute (RPM), rather than the relatively coarse control possible using the engine room telegraph. In the absence of the ability to remotely adjust engine revolutions, the telegraph will need to be used and information concerning the engine revolutions for set telegraph positions should be communicated before commencing the approach.
- At night the deck should be adequately lit and, if possible, the ship's side and fenders should be illuminated.
- The side for mooring should be clear of all overside obstructions.
- There should be effective radio communications between the bridge and mooring personnel on each ship. Communications should be tested before commencing the approach and agreement reached on a back-up method in the event of a communication failure.
- There should be effective communications between the bridge teams of each ship. This should be maintained on a separate frequency to those being used for internal radio communications on each ship.

LNGC Vessels will berth with their port side alongside the FSRU Terminal's berth. The FSRU Terminal is provided with mooring line tension monitoring systems.

To avoid damage to the FSRU Terminal's Fendering system, the LNGC Vessel must normally be landed squarely (in parallel) onto the FSRU Terminal's fenders with a contact speed not exceeding 0,10m/sec.

The LNGC Vessel's Master and the STS Superintendent will agree on the final position in accordance with the LNG Vessel's and FSRU Terminal's cargo handling arrangements (hoses spotting line). It is expected that the LNG Vessel must be ready to commence loading as soon as practicable after the completion of mooring, and it must complete loading, safely, effectively, and expeditiously taking into account the prevailing and expected weather conditions and relevant operating conditions.

Further guidance on the manoeuvring/berthing approach will be provided through the Joint Plan of Operations shared prior to the STS operation.

#### 6.9.1. Approach Method

Approaching manoeuvres and methods will depend on various factors including weather conditions. General guidelines and details regarding the tug arrangement can be found below.

The manoeuvre to reach the Terminal is an open water manoeuvre, characterized by the possibility to set and define the approach strategy to the FSRU from the most convenient and efficient direction with respect to the environmental conditions. LNGC speed management along the approaching route

is required, especially after the swinging has been completed, to maximize the effect of bow thrusters and tugs.

Tug configuration is mostly dependent on metocean conditions: the configuration is composed by one tug fastened at bow, one tug fastened at stern and two tugs in push/pull at LNGC starboard side. Fore and aft tugs towing cable length shall be managed case by case based on prevalent metocean conditions direction.

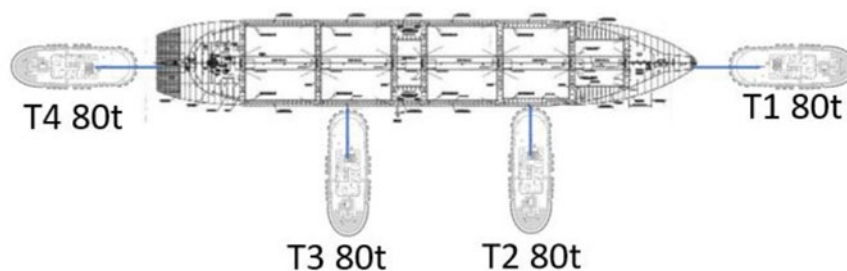

Figure 19 Typical Tug Arrangement

Figure 19 Typical Tug Arrangement, provides an indication of the typical arrangement of tugboats in an approach manoeuvre. T1 positioned at bow in pulling configuration, T2 and T3 pushing starboard side, T4 positioned at stern in pulling configuration.



Figure 20 Tugs escorting the LNGC towards the FSRU

#### 6.9.1.1. Berthing Manoeuvre Scenarios

The type of manoeuvre depends on the prevailing weather conditions. The FSRU ALEXANDROUPOLIS is depicted with red colour, the LNGC carrier with black colour and the available tugs (four in total) with blue colour.

**Berthing Plan A** (Wind direction: 45° NE, Wave direction: 45° NE)

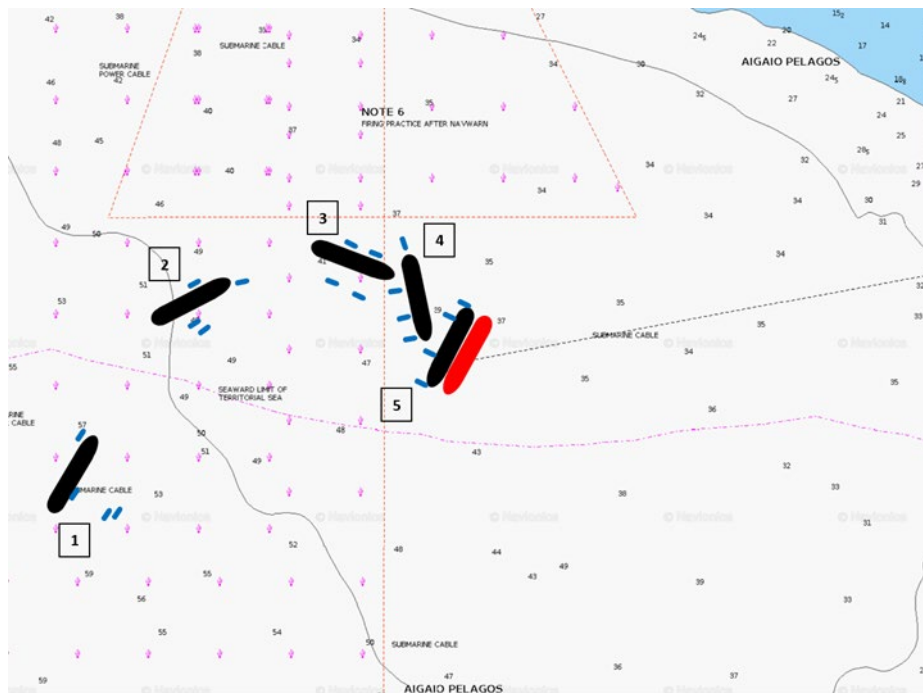

Figure 21 Berthing Plan A

**Berthing Plan B (Wind direction: 295° WNW, Wave direction: 295° WNW)**

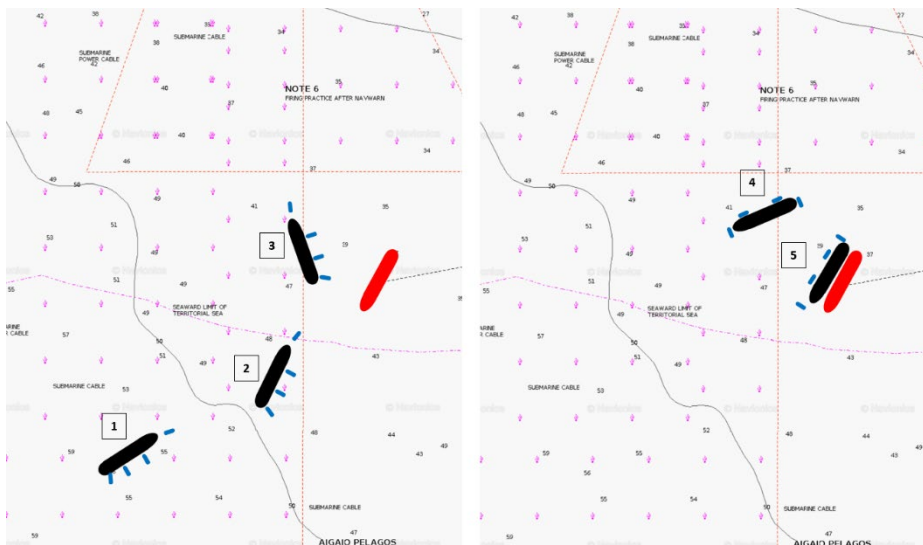

Figure 22 Berthing Plan B

**Berthing Plan C (Wind direction: 295° WNW, Wave direction: 295° WNW)**

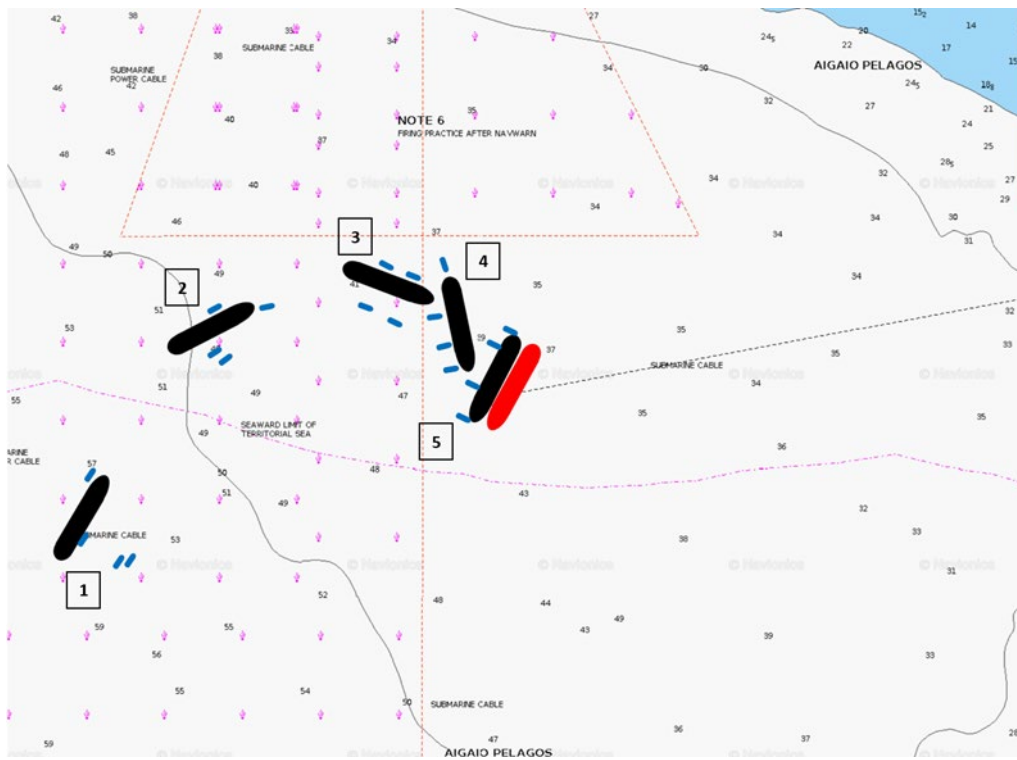

Figure 23 Berthing Plan C

**Berthing Plan D (Wind direction: 45° NE, Wave direction: 45° NE)**

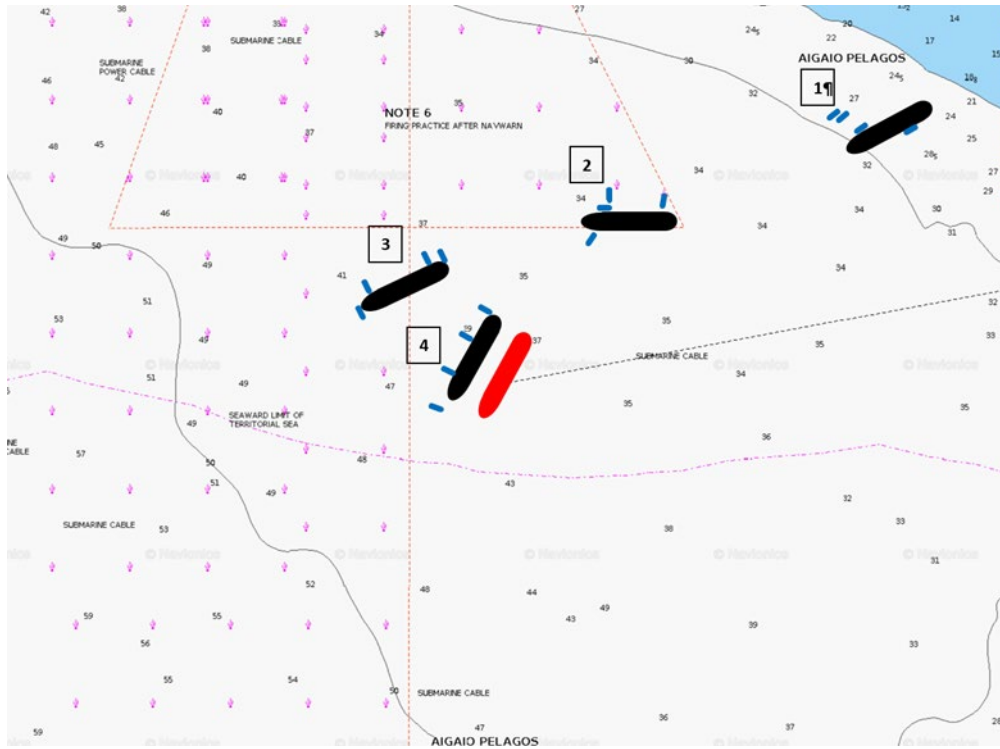

Figure 24 Berthing Plan D

**Berthing Plan E (Wind direction: 135° NE, Wave direction: 135° NE)**

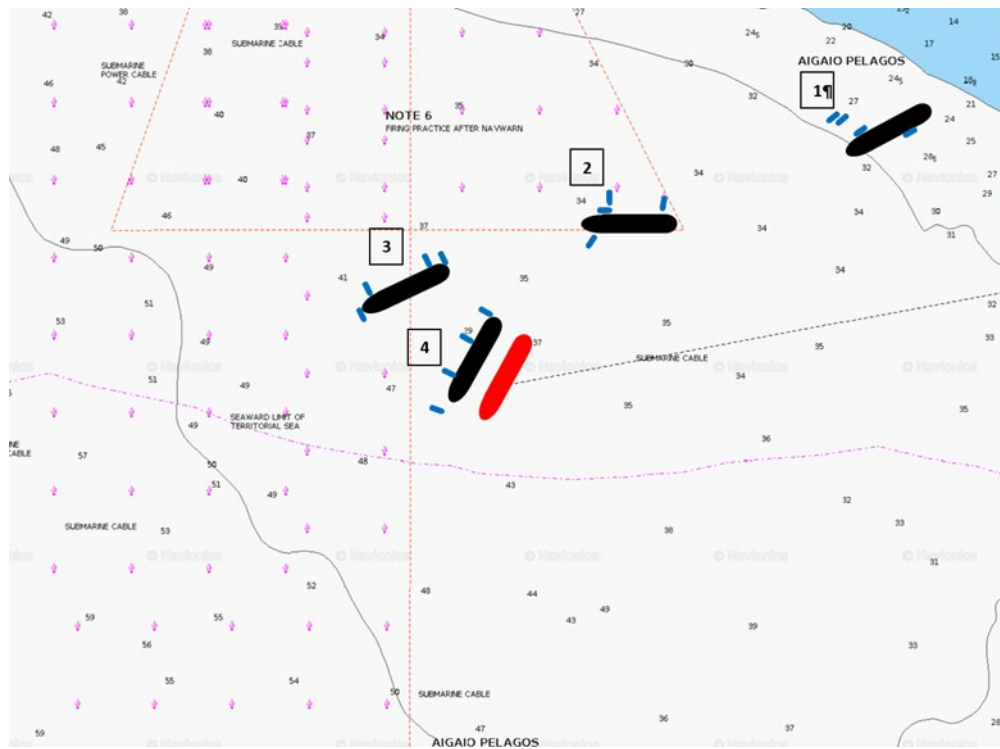

Figure 25 Berthing Plan E

## 6.10. Night Berthing Operations

Night berthing operations can be conducted based on the following criteria and should be assessed in conjunction with the appointed STS Superintendent and both Masters, during the preparation of the JPO and toolbox meeting:

- Visibility at the area
- Availability of tugs
- Local traffic should allow for such operations
- Experience of crew. Deck officers and ratings should be aware of associated hazards
- Adequate deck lighting which does not obstruct deck operations at the participating vessel
- Weather conditions should be calm
- Bridge Wing Search Lights to be tested working and pointing to fenders, with due consideration on not to be pointing directly towards the Bridge of the other vessel. Also, no lights to be overhanging and protruding beyond vessel's maximum breadth
- Experience of STS Superintendent should be adequate for night berthing operations. Service Provider to confirm that provided STS Superintendent has adequate night berthing experience for the involved type of vessels
- The Service provider should have already cleared the STS location and approved it for night berthing
- The STS Superintendent and Service provider should present a risk assessment with reasonable risk mitigation measures for night berthing for the STS Location
- Any restrictions from the local authority

## 6.11. Procedures for calculating the berthing Energy

The purpose of this section is to clearly define the procedures associated with the calculation of Berthing Energy (BE) exerted on primary fenders during the first contact. The calculation will provide guidance to the Master of LNGC calling at FSRU terminal, in order to properly understand and interpret the berthing energy exerted on primary fenders.

Upon reviewing of this procedure, the Master of LNGC vessel will be confident on how to prevent a contact with higher approaching velocity and possible damage on fenders. The approaching process should also be discussed with the pilots and the STS Superintendent.

### 6.11.1. The approaching Velocity

The approaching velocity is the lateral/relative velocity associated with the forces exerted on the primary fenders during the initial contact/landing of the LNGC onto the FSRU terminal. The pressure on fenders increases as the approaching velocity also increases. In this respect, it has to be ensured that the pressure exerted on primary fenders will not exceed the operating limits as mentioned in the latest OCIMF guidelines.

According to (ICS/SIGTTO/OCIMF/CDI, 2013) guidelines Appendix H:

*“The approach velocity of the ships can have a dramatic effect on the berthing energy absorption requirements of the fender system. The allowance for velocity should take into consideration the effects*



of local weather, sea and swell conditions, tug or thruster availability and the physical size of the ships involved.

*It is common to work within a range of about 0.1 to 0.3 meters per second (0.2 to 0.6 knots) and it should be noted that an increase of about 0.02 (m/sec) (0.04 kts) in velocity could result in approximately 28% increase in energy absorption requirements should the berthing speed be in the range of 0.15 m/sec, and 20% increase should the berthing speed be in the range of 0.20 m/sec. Also note that smaller ships tend to have higher berthing velocities.”*

The LNG Master should be aware of the maximum lateral velocities (approaching speed) during berthing. Such speed should not exceed the manufacturer recommendations.

### 6.11.2. The approaching angle

The LNG ship will make the initial contact on the FSRU terminal at an oblique angle. Given the fact that the weather conditions are CALM and there is no pressure by tugs, the factors which considered of equal significance are the approaching speed (lateral velocity) and the approaching angle.

In order to properly estimate the approaching angle, the LNG Master should be aware of the below triangle shape,

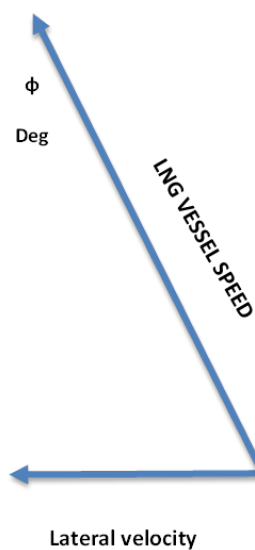

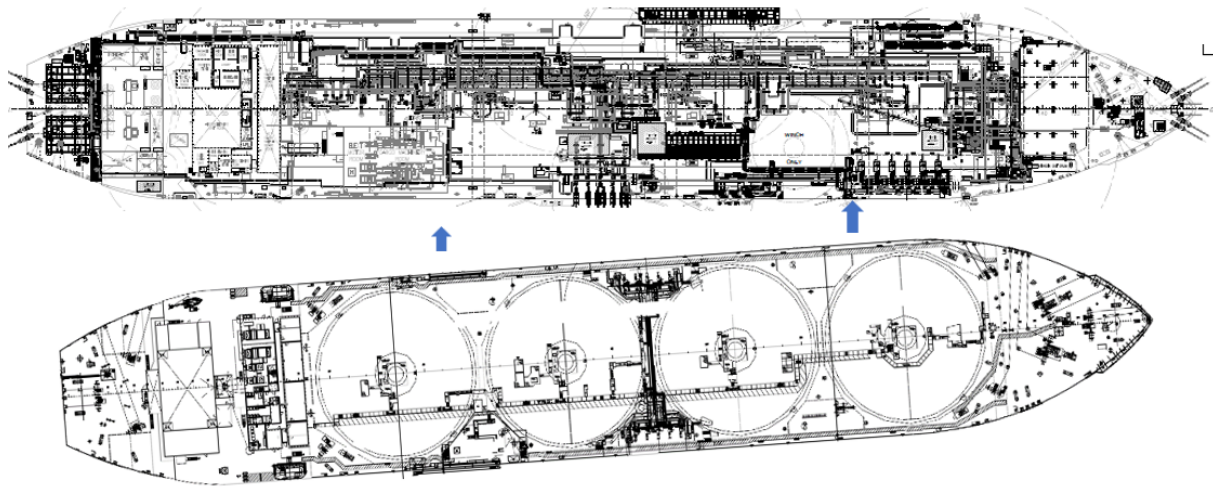

Figure 12 Angular Berthing

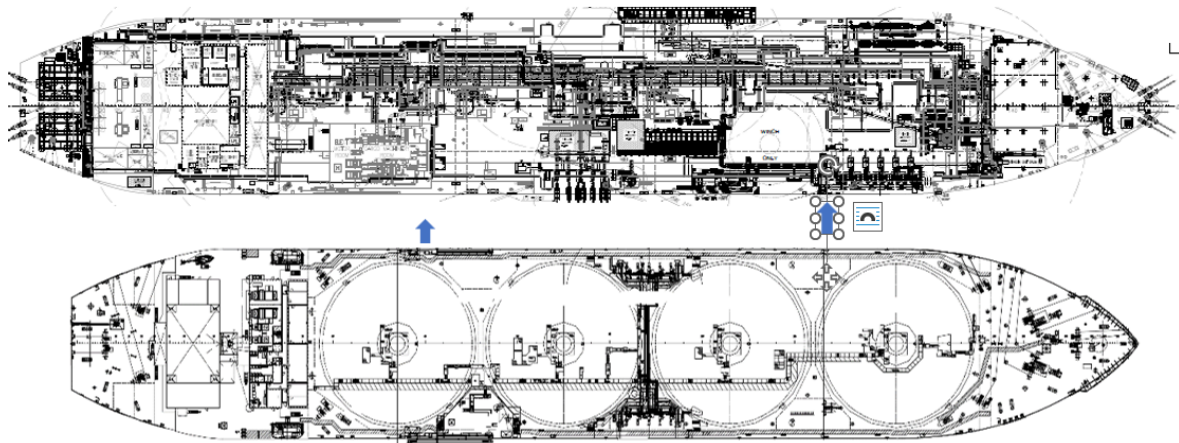

Figure 13 Parallel Berthing

The approaching velocity is extracted from the following formula.

$$\text{Approaching velocity } \left[ \frac{m}{s} \right] = \sin(\varphi) * (\text{manoeuvring vessel Speed [Kn]}) * \left( \frac{1852}{3600} \right)$$

The following Table 9 depicts the approaching velocity in relation to the angle (Y-axis) and LNGC vessel speed (X-Axis).

		APPROACHING (LATERAL) VELOCITY IN [m/s]									
		LNGC SPEED									
		1 Kn	2 Kn	3 Kn	4 Kn	5 Kn	6 Kn	7 Kn	8 Kn	9 Kn	10 Kn
APPROACHING ANGLE	3 deg	0.03	0.05	0.08	0.11	0.13	0.16	0.19	0.22	0.24	0.27
	4 deg	0.04	0.07	0.11	0.14	0.18	0.22	0.25	0.29	0.32	0.36
	5 deg	0.04	0.09	0.13	0.18	0.22	0.27	0.31	0.36	0.40	0.45
	6 deg	0.05	0.11	0.16	0.22	0.27	0.32	0.38	0.43	0.48	0.54
	7 deg	0.06	0.13	0.19	0.25	0.31	0.38	0.44	0.50	0.56	0.63
	8 deg	0.07	0.14	0.21	0.29	0.36	0.43	0.50	0.57	0.64	0.72

Table 9 Approaching Velocity in relation to Angle and LNGC Speed. The table is indicative to depict the relation of vessels' speed with the approaching velocity. **Approaching LNGC speed should not exceed 2 knots.**

**Note**

The Master of the LNGC should be vigilant in case the approaching velocity exceeds the 0.30 m/s.

### 6.11.3. Weather conditions related to fendering and berthing criteria

For adverse weather conditions, other than CALM, guidelines from YOKOHAMA fender manufacturers include relevant maximum recommended approaching velocity for each weather condition,

DWT	Calm	Moderate	Rough
Less than 10,000	– 0.15 m/s	0.18 – 0.30 m/s	0.40 m/s –
10,000– 50,000	– 0.12 m/s	0.15 – 0.25 m/s	0.30 m/s –
50,000–100,000	– 0.10 m/s	0.12 – 0.18 m/s	0.20 m/s –
Over 100,000	– 0.10 m/s	0.12 – 0.18 m/s	0.20 m/s –

Table 10 Table 7-3 from Yokohama floating fenders 50& 80

### 6.11.4. Maximum allowable berthing energy

Below Table denotes the Berthing Energy exerted during first contact which should not exceed the Guaranteed Energy Absorption of the fender. For Fenders 4,5 x 9,0 50 kPa the GEA is 4752 kNm as shown at Table 12

The Master of the LNGC should avoid approaching velocity that may generate Berthing Energy, greater than 4752 kNm

GT	VW (T)	V (m/s)								
		0.10	0.12	0.15	0.18	0.20	0.25	0.30	0.40	
1,000	4,454	11.0	16.0	25.1	36.1	44.5	69.6	100	178	
2,000	8,183	20.5	29.5	46.0	66.3	81.8	128	184	327	
3,000	11,672	29.2	42.0	65.7	94.5	117	182	263	467	
4,000	15,031	37.6	54.1	84.5	122	150	235	338	601	
5,000	18,191	45.5	65.5	102	147	182	284	409	728	
6,000	21,384	53.5	77.0	120	173	214	334	481	855	
8,000	27,586	69.0	99.3	155	223	276	431	621	1,103	
10,000	33,604	84.0	121	189	272	336	525	756	1,344	
12,000	39,440	98.6	142	222	319	394	616	887	1,578	
15,000	47,921	120	173	270	388	479	749	1,078	1,917	
20,000	61,687	154	222	347	500	617	964	1,388	2,467	
25,000	75,086	188	270	422	608	751	1,173	1,689	3,003	
30,000	88,121	220	317	496	714	881	1,377	1,983	3,525	
40,000	109,372	273	394	615	886	1,094	1,709	2,461	4,375	
50,000	129,723	324	467	730	1,051	1,297	2,027	2,919	5,189	
60,000	149,117	373	537	839	1,208	1,491	2,330	3,355	5,965	
80,000	185,834	465	669	1,045	1,505	1,858	2,904	4,181	7,433	
100,000	221,472	554	797	1,246	1,794	2,215	3,461	4,983	8,859	

Table 11 Berthing Energy for Gas Carrier (kNm)

Nominal Size Diameter × Length	Initial Internal Pressure	Guaranteed Energy Absorption GEA	Reaction Force at GEA	Hull Pressure at GEA	Safety Valve Setting pressure	Testing Pressure	Weight of Net Type (Type I )			Weight of Sling Type (Type II)	
							Approx. Fender Body Weight	Approx. Weight of Net			
								Chain Net	Wire Net		Synthetic Fiber Net
(mm × mm)	(kNm)	(kNm)	(kN)	(kPa)	(kPa)	(kPa)	(kg)	(kg)	(kg)	(kg)	(kg)
500 × 1000	50	6	64	132	-	200	22	110	30	20	32
600 × 1000	50	8	74	126	-	200	25	120	30	22	36
700 × 1500	50	17	137	135	-	200	45	150	40	37	55
1000 × 1500	50	32	182	122	-	200	73	200	80	51	98
1000 × 2000	50	45	257	132	-	200	88	220	140	57	113
1200 × 2000	50	63	297	126	-	200	131	320	190	68	156
1350 × 2500	50	102	427	130	-	200	200	350	200	-	240
1500 × 3000	50	153	579	132	-	200	250	530	350	-	290
1700 × 3000	50	191	639	128	-	200	290	580	440	-	330
2000 × 3500	50	308	875	128	-	200	405	960	640	-	465
2500 × 4000	50	663	1381	137	175	250	902	1240	910	-	1080
2500 × 5500	50	943	2019	148	175	250	1090	1850	1160	-	1320
3300 × 4500	50	1175	1884	130	175	250	1460	1710	1270	-	1840
3300 × 6500	50	1814	3015	146	175	250	1870	2570	1910	-	2250
3300 × 10600	50	3067	5257	158	175	250	2560	4660	3300	-	3060
4500 × 9000	50	4752	5747	146	175	250	3940	5390	3520	-	-
4500 × 12000	50	6473	7984	154	175	250	4790	6990	5190	-	-

Table 12 Guaranteed Energy Absorption (GEA) for YOKOHAMA fenders, ISO 17357

# 7. Mooring and Unmooring Operation

## 7.1. Mooring Plan

The proposed scheme for mooring lines arrangement can be traced at the 5. *PROPOSED MOORING PLAN* Chapter. The minimum mooring line pattern for LNGCs is indicated in the following table:

LNGC Size	Mooring Lines	Forward	Aft
Up to 3000 m <sup>3</sup>	Head / Stern / Breast	4	2
	Spring	2	2
Up to 7500 m <sup>3</sup>	Head / Stern / Breast	4	4
	Spring	2	2
Up to 10000 m <sup>3</sup>	Head / Stern / Breast	2	2
	Spring	2	2
Up to 20000 m <sup>3</sup>	Head / Stern / Breast	4	4
	Spring	2	2
Up to 145000 m <sup>3</sup>	Head / Stern / Breast	6	5
	Spring	2	2
Up to 170000 m <sup>3</sup>	Head / Stern / Breast	6	4
	Spring	2	2
Up to 180000 m <sup>3</sup>	Head / Stern / Breast	6	5
	Spring	2	2

Table 13 Recommended Mooring Pattern

Any deviation from the minimum mooring lines requirements shall be agreed and defined during the Compatibility Study Process. However, the LNGCs should be ready to use all available mooring lines and the LNGC's Master should not hesitate consulting the STS Superintendent, and if needed, to increase the number of mooring lines deployed, if he considers it is prudent to do so.

All mooring lines must be deployed on mooring winch drums and be capable of effectively mooring the LNG Vessel.

The arrangement of mooring lines and the sequence of the mooring operations shall be agreed upon in advance between the LNG Vessel's Master, the Pilots and the advice of the STS Superintendent.

## 7.2. General Considerations

Any mooring lines attached to the same mooring hook of the FSRU Terminal or run in the same direction (e.g. forward) shall be of a similar breaking strength and comprise the same materials. The LNGC's crew must deploy the mooring lines in accordance with the advice of the STS Superintendent and the agreed mooring plan. Where split drums are fitted, mooring lines must be properly reeled in accordance with OCIMF "Mooring Equipment Guidelines."

The LNG Vessel's mooring equipment shall be maintained in good condition to meet the requirement of always keeping the LNGC in a proper and safe position alongside the berth. Certificates and inspection data of LNG Vessel's mooring equipment shall be made available by the Master to the STS Superintendent on request.

The safety of the moored LNGC is the Master's responsibility under all circumstances. However, to ensure safe cargo handling and to avoid damage to the FSRU Terminal, the STS Superintendent and FSRU Terminal's deck watch personnel will periodically check the LNGC's moorings, to ensure that they are satisfactory. If they are not, the STS

Superintendent will request the LNGC's Master to adjust the moorings or take such other steps as considered necessary. If the Master does not fulfil the STS Superintendent request in reasonable time or in extreme cases (i.e. safe operation or the FSRU Terminal's integrity is jeopardized) the STS Superintendent may take such steps as are considered necessary.



Figure 26 Stern Lines Mooring

## 7.3. Mooring

The ALEXANDROUPOLIS is orientated on a heading of 205 N (SSW) and held in position by a restricted catenary mooring (RCM) system, or spread mooring system, where four set of three mooring lines are deployed. Mooring should only commence following the confirmation and completion of the relevant checklists.

Bow and stern thrusters should be utilized where available, however consideration should be given to the effect of these on the ALEXANDROUPOLIS.

The Mooring Plan adopted for a particular STS operation will depend on the size and characteristics of the LNGC. The suitability of the Mooring Plan will be agreed and proven through the Mooring Analysis

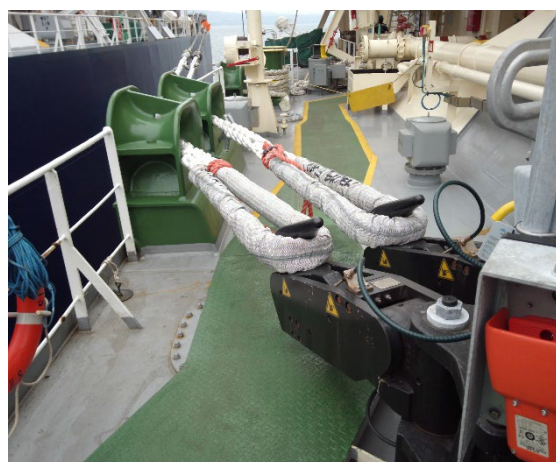

Figure 27 FSRU ALEXANDROUPOLIS - Mooring Hooks

completed during the Vessel Compatibility stage. Mooring Operations should be managed to ensure prompt and efficient line handling.

**Note:** Both Vessels should be prepared to abort, if necessary, any manoeuvring operations. The International Code for Preventing Collisions at Sea must be complied with.

The use of suitable rope messengers typically of 40mm diameter should be employed to bring the LNGC mooring lines onboard placing the eye of the mooring tail on the corresponding hook.

The first lines sent from the LNGC will usually be the spring lines followed by the head and stern lines. The spring lines should be utilized to aid the alignment of the Vessels vapor manifolds.

All Fast will be declared at the time when the LNGC is safely moored with all mooring lines tied up to the ALEXANDROUPOLIS to the satisfaction of the LNGC Master.

Upon completion of the mooring operation the quick release hooks are to be made ready in the correct mode for rapid casting off of the lines should it become necessary. Attention should be given to all moorings throughout the operation to avoid excessive or uneven line tension. Adjustment to the moorings should only be made under the guidance of the STS Superintendent and when agreed between both Vessels.

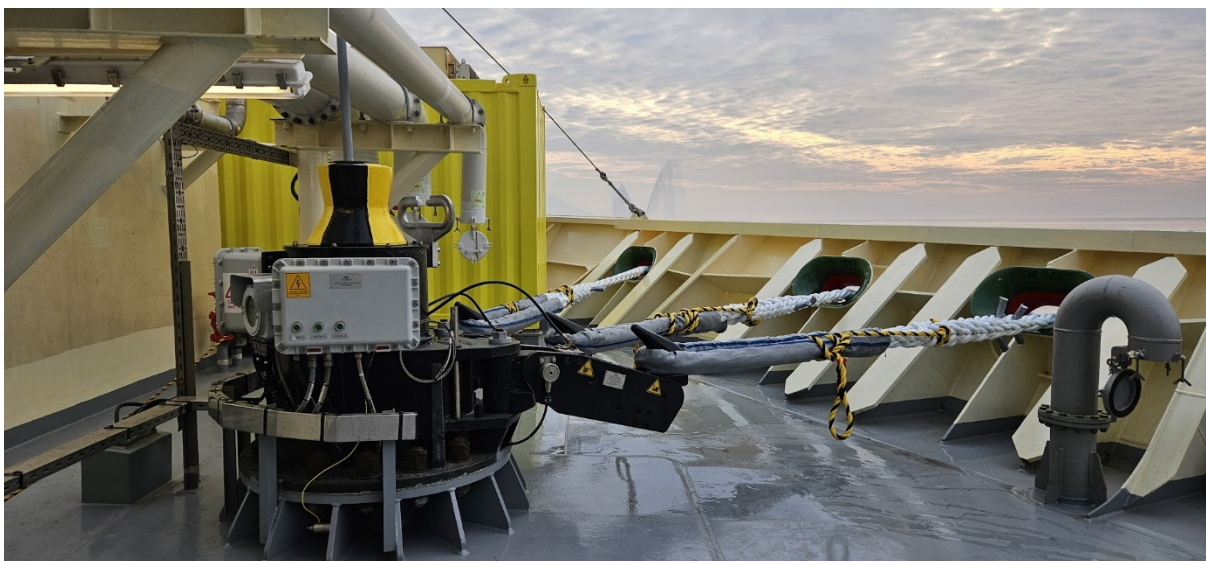

Figure 28 Mooring forward Hooks

#### 7.4. Mooring Lines Monitoring

When mooring operation is completed, the Master of the LNGC must ensure the following:

- The STS Superintendent has reviewed mooring configuration to be in compliance with the approved mooring plan
- The LNGC is safely moored.
- A sufficient number of deck watchkeepers are on duty.
- Line tending operations are carried out as appropriate to ensure the LNGC is held firmly alongside in its correct position with respect to the hard arms. Line tending checks also ensure that mooring lines do not become too slack or too taught.



- When the LNGC is secure in the berth, the mooring winch brakes are properly hardened up and the winch is taken out of gear.

All FSRU Terminal mooring hooks are equipped with load sensors and all measurement values are collected to the central control room of the Terminal for continuous monitoring.

All Terminal mooring hooks are equipped with load sensors and all measurement values are collected to the central control room of the Terminal for continuous monitoring.

Line tension monitoring system has adjustable set points for Low and High Alarm which are shown on the table below. An alarm panel at the top of the screen indicates any current alarms. The alarms are triggered at the following points:

	QRH 1	QRH 2	QRH 3	QRH 4	QRH 5	QRH 6	QRH 7	QRH 8
High Alarm (t)	50	50	50	50	50	50	50	50

*Table 14 Mooring Hooks Load Limits*

However, if appropriate, the alarm set points can be adjusted as per the mooring plans. On activation of a high or low mooring tension alarm immediate action will be required to rectify the tension of the alarmed mooring line(s).

When the LNGC is alongside the mooring line tension system should always be monitored by FSRU Terminal panel operator. LNGC control room at any request can receive and advice the recorded values. Slack or over tension of lines should be immediately referred to the LNGC control room for readjustment of lines.

## 7.5. Unmooring

At the end of the cargo operation and prior to the unmooring operation, the relevant checklist should be completed and agreed between the ALEXANDROUPOLIS and the LNGC.

A toolbox talk shall be carried out by the STS Superintendent and shall include the LNGCs Captain, duty officer and forward and aft mooring teams where applicable.

In the agreed sequence, generally from out to in leaving the spring lines to last, the mooring lines will be slackened back prior to the activation of the release hooks.

Further details of the Mooring and Unmooring Operation will be shared in the specific Joint Plan of Operation (JPO) issued before each STS and will detail the Mooring and Unmooring sequence.

## 7.6. Unberthing procedures

All manoeuvring of LNG Vessels proceeding without the Exclusion Zone must be conducted with appropriate care and caution at a speed and in a manner that must not endanger the safety of other vessels or the FSRU Terminal.



*Figure 29 Vessel Unberthing*

The unberthing principle is to manoeuvre the LNG Vessel into a position parallel of the FSRU Terminal's berth at about 100 meters off and moving forward.

The tug forward and aft will be made fast. The middle tugs will be ready to push if necessary and maintain the LNG vessel alongside the FSRU terminal.

All lines will be single up and during this operation, attention will be focus on the longitudinal speed of the LNG vessel.

Once the LNG Vessel is single up, the 2 last lines will be let go from the FSRU Terminal. If necessary, the middle tug will push alongside. The middle tug can be made fast in push/pull position. When all lines are clear, the 2 tugs forward and aft will start to move astern. The LNG Vessel will have to move sideways and forward.

All available tugs will pull out the LNG Vessel out of the 500 m zone of the FSRU Terminal. The 4 tugs will not cast off before the LNG VESSEL is out the agreed distance zone.

## 8. General Safety

The safety standards have been formulated in accordance with OCIMF (ISGOTT), SIGTTO, and other widely recognized industry accepted standards. The STS Superintendent should ensure that all safety aspects are met with utmost importance and in case of infringement of safety, or security, this should be brought to the attention of the Master of LNGC.

The LNGC's personnel bear the responsibility for ensuring the safety of the vessel. The LNGC's Master and crew are obligated to observe all essential safety measures and follow the advice of the STS Superintendent. This includes considering the risks associated with LNG loading operations, prevailing weather conditions, and any other circumstances demanding heightened care or caution. The Master of the LNGC has the responsibility of his ship, cargo and equipment transferred for the STS Operation.

### 8.1. Crew preparedness and readiness

At all times sufficient crew must be ready on board the LNGC and FSRU Terminal to guarantee that the correct level of personnel is available to respond to any emergency situation that may occur, including emergency unberthing.

### 8.2. Engine Safety

To prevent inadvertent operation of the LNG Vessel's main engine while the flexible hoses are connected, the next steps should be followed:

1. The LNGC must close and secure all propulsion main/master valves and isolate propulsion by means of turning gear engaged, confirming the isolation to the FSRU terminal. This is to be done after the "all fast" declaration by the LNGC Master and prior to starting to connect the flexible hoses or any personnel transfer.
2. Auto spin must be off, and the turning gear engaged until flexible hoses are disconnected.
3. The FSRU Terminal will give formal permission to the LNGC to remove the seal and the turning gear as soon as the flexible hoses are disconnected and clear of the LNGC.
4. The LNGC Master must ensure that the engine is sufficiently warmed up and ready for a full range of operations before unmooring operations are commenced.
5. Test of engine to be done once pilot is onboard and tugs are made fast.
6. It is the LNGC Master's responsibility to advise the pilot and the FSRU Terminal OIM if there are any limitations on the range of use of the LNGC's main propulsion.

### 8.3. Repairs and Maintenance Works

Repair and maintenance activities, whether involving hot work or cold work, are strictly prohibited on the LNGC unless written permission is obtained from both the Plant Manager and the Maritime Authority / Coast Guard. Approval for repair and maintenance work must be obtained well in advance, at least 72 hours before the vessel's arrival, and should not coincide with cargo operations. During such periods, strict adherence to the Work Permit system is required as part of Terminal precautions.

In the event of an unavoidable breakdown of the LNGC, repairs may be considered, and the vessel may be permitted to remain alongside upon receiving written approval from the Terminal Manager.

However, if the mobility of the LNGC is compromised, the permission to stay alongside is conditional. In such cases, the LNGC's Master must arrange for an additional tug to facilitate movement, and the Maritime Authority / Coast Guard must be informed accordingly.

### 8.4. Leakage, Spillage of LNG and Fire Fighting

The LNGC must be equipped with protective measures to mitigate the consequences of LNG spillage and leakage. This can involve implementing provisions for containing LNG spills, ensuring the brittleness protection of carbon steel structural components, employing a water curtain, or implementing other suitable measures. Closed-circuit monitoring systems may be utilized to aid in detecting leakage.

The LNGC's fire and gas detection system, as well as its firefighting equipment in compliance with the SOLAS Convention and the IGC Code, must be always fully operational and prepared for immediate use, as outlined in the LNGC/shore safety checklist. A safety plan, in accordance with relevant IMO conventions, should be present on board the LNGC.

A plan displaying the location and type of all firefighting equipment on or near the FSRU Terminal must be permanently exhibited, along with any necessary instructions and firefighting procedures. Measures must be in place to safeguard personnel, structures, and essential equipment from a fire to minimize the risk of incident escalation. These measures may include water spray, water monitors, or passive fire protection measures.

Water monitors and sprays should be operable from a safe location, with water sprays proving effective in limiting the spread of gas clouds.

#### 8.4.1. Emergency Towing-Off Pennants

Emergency towing wires (fire wires) are required to be Correctly Rigged and Positioned and shall be made fast to bitts as far forward and as far aft as practicable on the side of the vessel opposite to the cargo connections.

The wires shall be in good condition and secured with a minimum of five turns on the bitts. The wire shall lead directly to the chock with no slack on deck and a heaving line made fast to the eye shall be used to always maintain the eye of the wire between one and two meters above the water. The wires shall be regularly checked and adjusted.

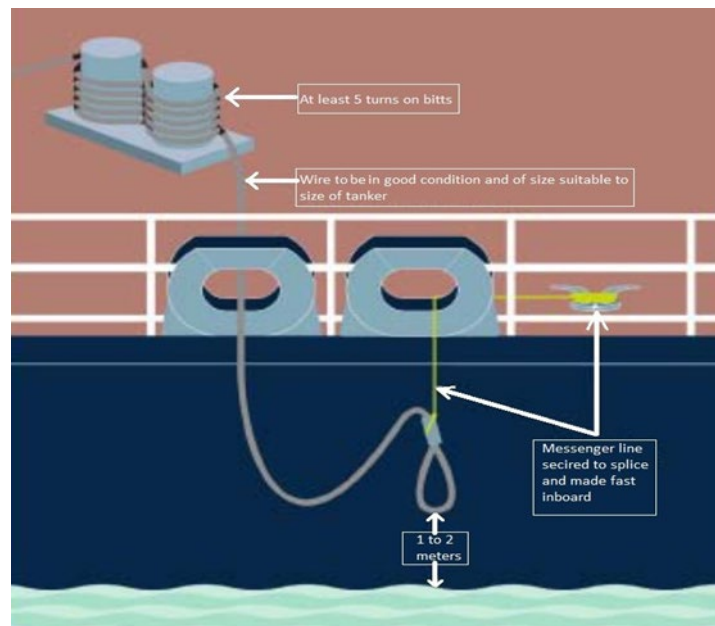

Figure 30 Fire Wire Messenger Line

## 8.5. Personnel Protective Equipment

It remains the LNGC's Master's responsibility to ensure that his crew always wear appropriate personal protective equipment on the LNGC while it is inside the Exclusion Zone. It is recommended for the LNGC's crew to wear the following:

- Lifejackets, when working close to the water's edge
- Eye protection
- Hard hats
- Long-sleeved overalls
- Leather gloves
- Safety Shoes

## 8.6. Environmental Considerations

Compliance with the applicable International Convention MARPOL 73/78 for the Prevention of Pollution from LNGC, which has been incorporated into Greek Law by L. 1269/1982 and subsequent amendments, is mandatory at all times.

The LNGC's Master must possess a written and approved SOPEP (LNGC oil pollution emergency plan) and hold a valid Oil Pollution Prevention Certificate (IOPP), as specified by Greek Ministerial Decisions.

It is the responsibility of the LNGC's Master to prevent any form of pollution to the sea or atmosphere, encompassing bunkers, LNG, bilge water, dirty ballast, plastics, garbage, or any other substances resulting in pollution. In the event of any pollution incident, immediate reporting is required to the Terminal Control Room and the Maritime Authority / Coast Guard.

### 8.6.1. Blanking Unused Manifold Connections

Ensure that unused cargo and bunker manifolds are appropriately blanked, with their manifold valves securely closed. Blank flanges should be fully bolted, and if other types of fittings are utilized, they must be properly secured. In the vicinity of any potential pollution area, deck scuppers, drain holes, and drip trays on the LNGC need to be suitably plugged, and any accumulated water or effluent must be drained off as needed.

### 8.6.2. Bunkering

The loading of bunker fuel and diesel oil is prohibited when an LNGC is berthed, and any internal transfer of bunker oil is not allowed.

### 8.6.3. Ballast Water Discharge

Discharging of clean segregated ballast from the LNGC is only permitted when the vessel is at the Terminal berth and, if deemed necessary, with prior permission from the Maritime Authority / Coast Guard and Terminal. The LNGC is required to uphold a Ballast Management System and maintain a properly filled Ballast Water Record Book (IMO), which should be accessible on board upon request from the STS Superintendent and other concerned parties such as the Maritime Authority / Coast Guard.

### 8.6.4. Air emissions

Each LNGC visiting the Terminal must adhere to MARPOL Annex VI (October 2008), as amended. The use of natural gas/boil-off and/or low sulphur fuel oil is required as fuel when the vessel is berthed alongside.

#### 8.6.4.1. Venting Cargo Vapours

While the LNGC is within port limits, the venting of cargo vapours to atmosphere is strictly prohibited.

#### 8.6.4.2. Inerting, Purging and Gas Freeing of Cargo Tanks

If any of these operations must be implemented, this has to be discussed at pre-arrival toolbox-meeting and pre-transfer meeting. A detailed plan for the relevant procedures has to be shown to FSRU in advance.

### 8.6.5. Waste Delivery

Waste delivery from the LNGC is strictly prohibited while alongside the FSRU. Also, discharging of any garbage or other materials, whether liquid or solid, overboard from an LNGC is strictly prohibited. Instead, such materials must be kept in appropriate receptacles onboard until specific arrangements are made for disposal by authorized subcontractors.

#### 8.6.1. Disposing Garbage Overboard

It is strictly prohibited to throw any material, paper, waste, or goods either solid or fluid overboard.

### 8.6.2. External Services

The following external services are allowed subject to approval by the FSRU Operations Manager and will be assessed on a case-by-case basis. The FSRU will have to be notified well in advance prior to each of the following tasks:

- Provisions or delivery of other supplies (Vessels/launch boats nominated for this purpose will have to be granted approval by the FSRU Operations Manager)
- Crew Changes
- Routine transportation route of Launch Boats
- Class or External Surveys and Services

### 8.6.3. Bilge and Sewage Discharge

The discharge of bilge and sewage effluents, oil, or any mixture containing oil to the sea is strictly prohibited. Bilge overboard valves must be visibly locked and sealed shut.

### 8.6.4. LNG Leakage

Should there be any LNG leakage, including vapour release, the LNGC's Crew must promptly halt cargo transfer or initiate the ESD system, as deemed suitable. If a gas cloud materializes and poses a threat to the FSRU Terminal, the FSRU Terminal will employ remote-controlled water monitors and other water spray systems to manage the gas cloud.

Operations can only recommence once the cause of the leakage is identified and fully addressed to prevent its recurrence. In the event of LNG leakage from the cargo hoses, the FSRU Terminal must immediately cease cargo transfer and take necessary measures.

The LNGC is obligated to maintain the water curtain at the shipside in the hoses area continuously during the periods when the flexible hoses are connected.

### 8.6.5. Water Supplies, Provisions and Spares

Water supplies, provisions, and spares are permitted exclusively when the vessel is at the anchorage.

## 8.7. Port Activities Restrictions During STS

Please note that below activities are restricted during the STS operation:

- Provisions /Spares /Lube Oils: Permitted only at the anchorage.
- Oil Waste /Sludge /Sewage /Garbage disposal to barges: Permitted only at the anchorage.
- Water supplies: Permitted only at the anchorage.
- Bunkering
- Maintenance and repairs: Strictly prohibited. At the anchorage with prior permission from the Maritime Authority/Coast Guard.
- Waste disposal via overboard: Strictly prohibited.

- Ballast water discharge: If necessary, discharging clean segregated ballast from the LNGC is allowed only at the Terminal berth and requires prior permission from the Maritime Authority/Coast Guard and Terminal.
- Embarkation and crew changes: Permitted.



# 9. Cargo Operation

## 9.1. Introduction

The regulations outlined in this chapter pertaining to terminal operations are founded on widely accepted safe practices within the LNG industry, with the primary objective of accident prevention. These protocols are designed to offer guidance to both LNGC and Terminal personnel, facilitating the achievement of efficient port operations.

Upon the LNGC reaching the terminal and being positioned alongside, the responsibility for cargo handling is jointly shared between the LNGC and the Terminal (FSRU). The following determinations and agreements should be established:

When the LNGC is alongside the Terminal, cargo operations shall not begin unless and until the LNGC's Master has:

- Acknowledged and signed the acceptance of these procedures/regulations.
- Inspected and completed the LNGC/Shore Safety Checklist or the corresponding checklist for the LNGC,
- Posted a Gangway Safety Notice (prohibiting Naked Lights, Smoking, and Unauthorized Persons).
- Displayed the LNGC's Fire Fighting plan on the deck.
- Ensured the water curtain at the manifold is in operation.

## 9.2. Pre-Transfer Meeting

Prior to the initiation of transfer operations, a pre-transfer meeting, led by the STS Superintendent is scheduled to take place on board the LNG Vessel in adherence to the Cargo Handling Transfer Procedures. The STS Superintendent and FSRU Manager are required to participate in this meeting. The designated individual(s) appointed by the LNG Vessel Master to oversee cargo handling operations on board must also attend, representing the LNG Vessel.

The primary objective of this meeting is to ensure a comprehensive understanding and documentation of all aspects related to cargo and associated activities, utilizing the FSRU Terminal pre-transfer meeting agenda.

In this meeting at least the issue below should be discussed and agreed:

- Confirmation of pre-arrival safety checks
- Mooring requirements and checks
- Status of cargo tanks on arrival (ROB/Heel, temperature and pressure)
- Custody transfer and CTMS status including BOG flowmeters
- Connection and disconnection of cargo flexible hoses
- ESD system testing procedure and sequence

- Cargo flexible hoses cool-down procedures.
- Discharging plan procedures and schedule
- Ballasting and draft requirements
- Procedures main steps and estimated required time.
- Weather forecast update.
- Review Communication means/check with FSRU Terminal
- Work permit requirements and LNGC's visitor's entry
- Communication and details of Stand-by Tug
- Security Patrol Boat duties
- Emergency procedures, including unmooring operations, departure, and evacuation plans.
- Security arrangements

### 9.3. Manifold Reducers

To allow the installation of the ERC's and the hoses to the visiting LNGC, the system is supplied with 16" to 10" reducers. There are 2pc "Y" reducers for installation on the vapour and one liquid manifold and 3pc conical reducers for the remaining liquid lines of both vessels.



Figure 31 Manifold Reducer

The visiting LNGC will not be required to remove their SDP's and will install the reducers prior to the connection of flexible hoses.

#### 9.4. Quick Connect Disconnect Coupling System

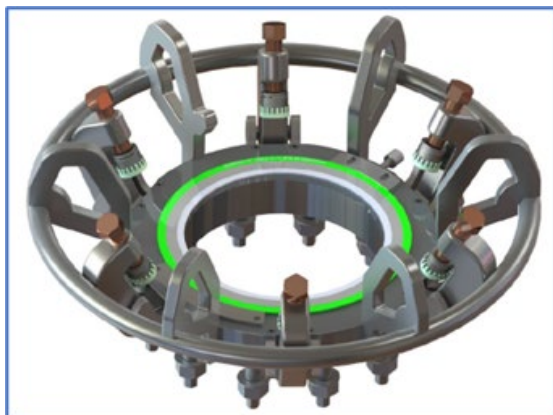

Figure 32 KLAW Cryo FC



Figure 33 KLAW Cryo FC

The Cryo FC is a clamp based quick connect/disconnect device utilized to connect the hose to any conventional bolted flange joint, including the manifold reducer.

The Cryo FC will be bolted to the floating flange of the hose in a pre-set position so that when the hose end is transferred to the LNGC the flange engagement plate is at 12 O'clock (+/- 30 degrees)

The mating face gasket is held in place by a retention plate and thumb screw, allowing a hands-free installation.

#### 9.5. Notice of Readiness to Discharge

Following the conclusion of the pre-discharge meeting, the LNGC's Master and an FSRU Terminal Representative (usually one of the C/O of the FSRU) are required to complete and sign a **Notice of Readiness** to discharge. This notice should explicitly indicate the time and date when the LNGC was prepared to initiate the discharge of cargo, along with providing information on the status of the cargo tanks.

#### 9.6. ESD Ship/Shore Communication Link

Primary Means of communication shall be Fibre Optic Cable.

The optical fibre ship/shore link (FO SSL) comprising 4 channels of multiplexed communication data and emergency shutdown signals of ship to shore and shore to ship where the ALEXANDROUPOLIS is designated the shore.

The signal to be transmitted between the ship station and the shore station.

ALEXANDROUPOLIS Side		Direction	Ship side	Channel No.
Audio signal	Tension monitor signal	→	Tension monitor signal	CH1

	Interphone audio signal (hot line telephone)	↔	Interphone audio signal (hot line telephone)	CH2
	Public Telephone audio signal	↔	Public Telephone audio signal	CH3
	Internal telephone audio signal	↔	Internal telephone audio signal	CH4
Dry connect signal	ESD (single Contact) signal	→	ESD (single Contact) signal	1 Point
	ESD (double contact) signal	←	ESD (double contact) signal	1 Point

Table 15 Signal Transmission Table

The secondary back up communication will be the 37 pin Pyle National connection will be provided by the FSRU.

Pyle Pin Configuration if required.

Pyle Pin Configuration		Mother Vessel	Daughter Vessel
5-6	Hot Line Telephone	Hot Line	Hot Line
13-14	ESD Ship to Shore	ESD Ship to Shore	ESD Shore to Ship
15-16	ESD Shore to Ship	ESD Shore to Ship	ESD Ship to Shore
17-18	Continuity Check	Continuity	Continuity

Table 16 Secondary back up communication

### 9.7. Water Deluge Systems (water curtain & bath)

The Fire Main shall always remain pressurized on both the FSRU and the LNGC.

Both the vessels shall have a water deluge beneath the cargo manifold, which is designed to protect the trunk slope or cargo tank weather cover. The water from the deluge collects in a bath under the cargo manifold to protect the main deck in case of LNG release.

The water bath shall be constructed by the LNGC using wooden planks (or fixed design) secured in place forward and aft of the cargo manifold.



Figure 34 Water Curtain / Deluge

Before line cooldown commences the hull water curtain and water deluge beneath the cargo manifold on both vessels shall be started.

### 9.8. Manifold Restriction Access During Operations

Once the LNGC is berthed alongside, access to the cargo manifold area is restricted to authorized vessels personnel only: Chief Officer, cargo engineer, deck officer on watch, Bosun and Abs on watch.

Restrictions that limit the number of personnel and the duration of there is enforced to minimize the exposure of all individuals entering the manifold restricted area.

Easily removable plastic chain or barricade tape with placard “Danger – Barricade area – Do not enter without authorization” should be used for restriction barrier.

CAUTION: Restriction barriers (tape or chain) shall be removed to prevent tripping hazards when persons are inside the restricted area

### 9.9. Pressure testing

Nitrogen is used to raise the pressure in the liquid and in the vapor line. The pressure is to be maintained while a leak test is carried out on the manifolds and hoses.

Once the leak test is complete the pressure can be released to the atmosphere and the atmosphere of the hose tested. Purging is considered complete once the oxygen content is less than 5% by volume. All cargo flexible hoses shall be depressurized after the test.

### 9.10. ESD Testing

Both Vessels should test their ESD system not more than 48 hours before the transfer operation and the tests should be documented and recorded.

ESD testing will be completed under warm conditions. The first test will be initiated from the FSRU to the LNGC, the second test will be initiated from LNGC to FSRU.

No Cold ESD testing will be conducted, following the completion of cooldown a cold stroke test of the manifold ESD valves will be conducted prior to commencement of cargo transfer.

### 9.11. Cooldown

The cooldown of the STS equipment and hoses is conducted using the LNGC spray pump. The STS checklist and the ship/shore safety checks will have been completed and the opening custody transfer initiated on both Vessels.

The spray pump will be lined up through the manifold cooldown valves on both Vessels. Maximum flow rate will be 50m<sup>3</sup>/hr.

Cooldown is complete when the manifold, STS equipment and hoses fall below -100oc and frosting occurs on the system. This will take approximately 60 minutes but may vary. Once the transfer system is cooled down, the spray pump can be stopped, and the double shut valves opened and the Cold Stroke test of the ESD valves can now be conducted.

Subject operation and procedures will also be discussed at pre-transfer meeting.

### 9.12. Cargo and BOG Management

The vapor manifold should be opened on both Vessels as soon as operationally practicable unless the FSRU tank pressures are lower than the LNGC.

When both Vessels are ready and lined up for cargo transfer the LNGC will start their first pump at the requested rate of the FSRU. Once cargo transfer has been established the LNGC at the request of the FSRU will ramp up to full rate whilst closely monitoring the vapor pressure of both Vessels.

Full loading rate will be determined by:

- Maximum pressure at the LNGC manifold (5 bar) or
- Combined maximum flow rate of the hoses (5 liquid hoses equals max rate of 11,250 m<sup>3</sup>/hr) or
- Allowable FSRU vapor header pressure of 350 m.barg;

Throughout the transfer operation at each whole hour, both Vessels will communicate and advise the status of the transfer.

- Quantity discharged/loaded.
- Quantity on board.
- Discharge/loading rate (average last hour).
- Vapor header pressure.
- Est Time to ramp down (Vessel dependent on either full discharge or fully loaded as agreed at the opening safety meeting).
- Manifold pressure (LNGC).

**CAUTION:** If the cargo tank pressure continues to increase with all BOG gas consumption measures in use (fuel gas burning / GCU / regasification boiler/ Recondenser) then the transfer rate should be reduced or stopped until vapor pressure can be controlled.

During the transfer, ballasting operations should be carried out to maintain the trim and list of both Vessels. Listing of either Vessel should be avoided except for proper tank draining.

#### 9.12.1. Vapor Management Procedures

Vessels are expected to maintain gas burning and utilize all available equipment to assist in tank pressure control of the terminal, such as the Gas Combustion Unit (GCU), Reliquefaction Unit or Subcooler, throughout their entire port stay at the FSRU ALEXANDROUPOLIS, subject to instructions received by the Loading Master and/or the STS Superintendent.

### 9.13. End of Cargo

Each tank filling valve should be adjusted as the tank approaches full capacity in line with the cargo loading plan.

**CAUTION:** Extreme and very high-level alarms and shutdowns are emergency devices only and should on no account be used as part of the normal topping-off operation.

Before topping off each cargo tank, the LNGC should be requested to reduce their discharge rate and continue to reduce their discharge rate when topping off each of the subsequent tanks.

When the tank is at its required filling level the corresponding filling valve should be closed. If it is convenient, finish loading by tank No.4 for ease of line draining and purging.

The transfer is stopped when the final cargo tank reaches a capacity according to the cargo plan minus the allowance for the line draining.

#### 9.14. Draining and Purging

**CAUTION:** Incorrect draining and purging of the cargo flexible hoses can cause damage due to effects of Rapid Phase Transition, pressure peaks and high gas flow velocities.

To aid the liquid free and purging process of the transfer flexible hoses, sea water spray should be directed to the “U” bend of each liquid hose.

Flexible hoses are to be made liquid free in two stages, firstly by initial displacement followed by pressure and release. Draining and purging will take place from the LNGC to the FSRU.

For the initial displacement, the double shut valves will be closed on the LNGC and nitrogen applied through the manifold connection on the LNGC. The nitrogen will displace the LNG towards the FSRU. Once the nitrogen reaches the bottom of the hose this process is no longer effective.



Figure 35 Hose Water spray process

Following the initial displacement, the ESD valves on both Vessels can be closed and the pressure in the hose raised to 3.5-4.5 bar. Once at pressure the FSRU ESD bypass valve is opened. The release of pressure causes the expansion of the nitrogen creating a piston effect on the liquid, carrying the LNG toward the FSRU.

This process is to be completed 3-4 times before checking the line for the presence of liquid.

One pressure and release cycle may be required from the FSRU to the LNGC to clear any trapped liquid at the manifold.

Purging the hoses will be conducted from the LNGC to the FSRU. Nitrogen will be applied at the manifold connection and raised to 1-1.5 bar. The pressure will be maintained, and flow established by the opening of the cool down valve and spay valve to the FSRU tanks.

Methane content of the hoses is to be checked prior to disconnection. Hoses are classed as purged when methane content is below 2% by volume.

### 9.15. Disconnection

The hose bun should be reinstalled on the hose to ensure that the flange connector, when suspended, will have a disconnection angle of 25°-30°.

The hose should be prevented from slipping over the saddle in reverse of the installation procedure before applying a small amount of lift by the FSRU Crane, to take the hose weight away from the flange connector.

The clamp bolts can be loosened, and the clamps swung back to the open position allowing the flange assembly to be disconnected. When the flange connection is clear of the manifold and in a suitable position the blanking flange can be reinstalled.

Once the hoses have been recovered, nitrogen should be applied to continually purge the hose, ensuring the methane content is not allowed to raise as it is released from the fibres of the hose. The hose should be maintained under a nitrogen blanket of 0.5 bar to prevent the ingress of moisture when not in use.

### 9.16. Transfer of STS equipment.

All equipment to be returned to the FSRU prior to the departure of the LNGC.

**CAUTION:** Water ballast must be drained from the saddles before lifting and returning to the FSRU

Fiber Optical ESD cable will be provided by the FSRU. Once the cable has been connected signals and communications should be checked.

None-fall arrest saddles and reducers will be transferred using the FSRU crane to the LNGC manifold. Reducers will then be installed as per the agreed manifold connections in line with the JPO, utilizing new gaskets made available from the LNGC.

Saddles are to be secured to the manifold using the securing Kit and filled with water ballast.



Figure 36 Transfer of Saddles

### 9.17. Roll-Over Effects

Roll-over is a spontaneous rapid mixing of LNG which occurs in large tanks because of density inversion, stratification develops when the liquid layer adjacent to a liquid surface becomes denser than the layers beneath, due to boil-off of lighter fractions from the cargo. The unstable situation relieves itself with sudden mixing, which the name 'roll-over' describes.

Roll-over can occur when boil off rates are greater than normal and cause an increase in pressure in the cargo tanks. If the cargo is stored for any length of time the boil-off gas is removed, evaporation can cause a slight increase in density and a reduction of temperature near the surface. The liquid at the top of the tank is therefore marginally heavier than the liquid in the lower levels, once stratification has developed, roll-over can occur.



Roll-over may happen on Vessels that have been stationary for extended period with a large volume of LNG in a tank(s). If such circumstances are foreseen, the tank contents should be circulated by the cargo pumps to prevent stratification occurring, reducing the risk of roll-over.

Roll-over can also occur if a similar or compatible cargo of different densities is loaded into the same tank.

#### 9.18. Cargo Measurements

The LNG Vessel's custody transfer measurement system must be in compliance with the industry standards, including:

- Calibration of LNG tanks
- Tank gauge approval and accuracy
- Liquid level gauging device accuracy, both primary and auxiliary systems
- Temperature gauging devices
- Pressure gauging devices

The FSRU Terminal Representative will be present and witness LNG measurement at the start and end of transfer operations.

The FSRU Terminal reserves the right to place a certified cargo surveyor on board the LNG Vessel.

#### 9.19. Post-Transfer Meeting

A post-transfer meeting is scheduled to take place on the LNG Vessel, in accordance with the Cargo Handling procedures. Attendance is mandatory for both the FSRU Terminal Representative, the STS Superintendent, and the designated responsible person(s) appointed by the LNG Vessel's Master for overseeing cargo handling operations on board.

This meeting serves as a platform to discuss any observations, concerns, or issues that may have arisen during the cargo transfer operations. The aim is to address these matters collaboratively, with a focus on identifying improvements that can enhance future operations.

#### 9.20. Terminal's Feedback Report

Following the completion of the Cargo Transfer, a feedback report will be shared with the LNGC Master. Record of feedback and past performance will be recorded online.

# 10. Emergency Procedures

The purpose of this section is to furnish guidelines for marine emergency procedures at the Terminal.

The paramount priorities in these procedures include safeguarding human life, preserving the environment, protecting the property of all involved parties, facilitating the swift recovery of the Terminal from a casualty, and resuming Terminal operations in a safe manner as expeditiously as possible.

It is crucial to note that these emergency procedures are to be executed concurrently with the Emergency Procedure/Plan of both the LNGC and the Terminal. This dual approach ensures a comprehensive and coordinated response, addressing both marine-specific contingencies and broader emergency scenarios involving the LNGC and the Terminal.

## 10.1. General Considerations

The safety requirements have been developed based on OCIMF (ISGOTT), SIGTTO and other industry accepted standards. The LNG Vessel's personnel are responsible for the safety of the LNG Vessel. The LNG Vessel's Master and crew MUST take all necessary safety precautions (whether or not so advised by the STS Superintendent), keeping in mind the hazards of LNG loading/discharging operations, weather conditions and any other circumstances requiring special care or caution.

In addition to LNG Vessel specific emergency procedures, the Master must take the following actions (from the first listed action to the last action) in the event of an emergency situation arising on the LNG Vessel or the FSRU Terminal.

The primary considerations are the safety of personnel and the protection of the integrity of the FSRU Terminal and the LNG Vessel. Quick response is essential in these situations and could require towing the LNG Vessel away from the FSRU Terminal.

## 10.2. Emergency Signal

An emergency on the FSRU will be indicated by seven (7) short one (1) long blast on the ships whistle. The emergency signal onboard the LNGC will be agreed at the opening STS Transfer Meeting.

## 10.3. Fire Prevention

Industry Standard practices and fire prevention measures must be adhered to ensure consistency with the Ship/ FSRU Terminal Safety Checklist, including the following:

- the LNG Vessel's fire control, safety plan and crew list must be posted adjacent to the pilot ladder/accommodation ladder and the accommodation entrance.
- The LNG Vessel's water spray system must be available for use at all times.
- the LNG Vessel's fire main system must be pressurized at all times.

- all of the LNG Vessel's fire hoses must be fitted with jet/spray branches to be available at each cargo tank dome area and at the cargo manifold area and must be connected to the
- LNG Vessel's fire main system, of sufficient length, and ready for immediate use
- The LNG Vessel's portable dry powder fire extinguishers must be placed in an accessible place near the manifold area in operation.
- the LNG Vessel's fixed dry powder system must be ready for immediate use, with control boxes opened for access
- all of the LNG Vessel's external doors, windows and portholes must remain closed
- the LNG Vessel's air conditioning and ventilator intakes likely to draw in air from the cargo area must be closed (however, air conditioning must be maintained on partial recirculation to maintain a positive pressure in the accommodation)
- the LNG Vessel's window type air conditioners (if fitted) must be disconnected from their power supply
- the LNG Vessel's main transmitting aerials must be disconnected and earthed while hoses are connected to the LNG Vessel
- the use of the LNG Vessel's RADAR whilst alongside the FSRU Terminal and during cargo handling operations is prohibited
- portable and fixed electric and electronic devices and equipment used in the LNG Vessel's hazardous areas must be of approved type for such areas and satisfactorily maintained so as to ensure that their original certificates are not jeopardized.
- the use of Naked Lights is strictly prohibited.
- smoking on board the LNG Vessel is only authorized in one designated smoking area, unless previously agreed upon during the pre-transfer meeting
- smoking and non-smoking signs must be displayed on board the LNG Vessel on arrival under the Master's authority
- hot work including hammering, chipping, and operations involving the use of any power tools are prohibited on board the LNG Vessel
- the use of mobile telephones and pagers is prohibited either within the FSRU Terminal or the LNG Vessel's hazardous areas, unless of an approved type (non-approved types must be switched off at all times)
- mobile telephones and pagers may be used on board the LNG Vessel but inside the accommodation area and with the Master's permission

In addition, the LNG Vessel must maintain a fire watch system, which includes routine monitoring of spaces and areas not continuously manned.

#### 10.4. Emergency Communications

Terminal/LNGC communications by LNGC/shore radio UHF channel			
In case of failure use either telephone or Marine VHF			
Source	Telephone Numbers	Emails	VHF channel
Terminal	VSAT: +30 2111990100 Iridium Certus: +881 677 116 704 FBB: +870 773 256 229 Mobile: (+65) 803 412 15	alx@gaslogserv.com	TBC
Maritime Authority / Coast Guard	+302551356200	alexandroupoli@hcg.gr	TBC
Stand by Tug	+306952351350; +306952351351; +306952351352; +306944934619	christos.pagidis@svitzer.com; fred.jeeninga@svitzer.com	TBC
FSRU Manager	+306932612103	c.tsoumaris@gastrade.gr	-

Table 17 Emergency Communications

#### 10.5. Emergency Cast-Off Procedures

In an emergency both Masters, in consultation with the STS Superintendent, should assess the situation and act accordingly.

- Criteria for an emergency cast-off includes, but is not limited to the following:
- Unexpected deterioration in wind, wave, or swell conditions
- Forecast indicating Weather deterioration exceeding the weather parameters.
- Primary fender failure.
- Mooring System failure.
- Cargo hose failure.
- Cargo Containment failure.
- Vapor release.
- Any other shipboard emergency which presents a risk to either ship involved in the operation.
- Local area emergency requiring the emergency departure of vessels.

Notice must be given to the other vessel when a breakaway is deemed necessary. The hoses and other connections at the manifold area should be correctly and promptly disconnected if time/situation allows.

During operations, the manifold area should be free from personnel if an emergency breakaway occurs. In the event of a breakaway, developing alarms must be raised and the relevant parties informed so that a plan can be implemented to ensure the safe movement of the vessels. Mooring squads and manifold disconnection personnel must be mustered and arrangements for safe and controlled breakaway made.

The contingencies in the risk assessment and emergency response must be followed where possible to ensure a safe breakaway is undertaken. Contingency action should be considered by both vessels in advance.

Emergency cast off procedures for LNGC vessels from FSRU Alexandroupolis are critical to ensure the safety of personnel, the environment, and the vessels involved.

The following steps are suggested to be followed:

- 1. Assessing the Situation:** Evaluate the reason for the emergency cast off. The STS Superintendent and both Master's should be in agreement for the cast off. They should assess factors such as adverse weather conditions, fires, mechanical failures, or security threats, however both Master's have the overriding authority towards ensuring safety.
- 2. Raising Alarm:** The first step is to raise the alarm and alert all crew members to both the LNGC vessel and the FSRU. Use the designated communication systems onboard to ensure all personnel are aware of the emergency.
- 3. Stop cargo transfer:** Stop any cargo transfer and initiate ESD2 procedures by manual activation. In case the emergency cast off has been planned to weather deterioration, this step could be by-passed. In this case and if weather deterioration is certain, then 10-12 hours before, hose disconnection should be initiated.
- 4. Tugs:** The STS Superintendent to inform the tugs about the planned cast off in order to arrive promptly at the FSRU location.
- 5. Communication with Authorities:** Establish communication with relevant maritime authorities, port authorities, and emergency services to inform them of the situation and seek assistance if necessary.
- 6. Emergency Tests:** Do a test on the rudder system and bow thrusters, if available.
- 7. Securing Cargo and Equipment:** Secure all cargo handling equipment, including cargo hoses, and valves, to prevent any spills or accidents during the cast-off process.
- 8. Preparing Vessel Systems:** Ensure all necessary systems on the LNGC vessel are ready for departure, including propulsion systems, navigation equipment, and emergency response equipment.
- 9. Preparing Mooring Lines:** Release mooring lines securing the LNGC vessel to the FSRU. This should be done systematically and under the guidance of the STS Superintendent, to avoid accidents or injuries.
- 10. Monitoring Gas Levels:** Continuously monitor gas levels and conditions onboard both the LNGC vessel and the FSRU to ensure safety during the cast-off process.
- 11. Coordinating with Tugboats:** The STS Superintendent should coordinate with tugboats for assistance in maneuvering the LNGC vessel away from the FSRU safely.
- 12. Executing Cast Off:** Once all preparations are complete and it is safe to do so, execute the cast-off maneuver, gradually increasing speed and distance from the FSRU while maintaining control of the vessel.

**13. Monitoring and Reporting:** Continuously monitor the situation during and after the cast-off, and report back to relevant authorities and stakeholders regarding the status of the vessel and any further assistance required.

**14. Safety Checks and Debriefing:** Conduct safety checks on both the LNGC vessel and the FSRU after the emergency cast off to ensure no damage or hazards exist. Hold a debriefing session with the crew to review the emergency response and identify any lessons learned for future improvement.

## 10.6. Emergency Scenarios

### 10.6.1. Emergency Signal

An emergency on the FSRU will be indicated by seven (7) short one (1) long blast on the ships whistle. The emergency signal onboard the LNGCC will be agreed at the opening STS Transfer Meeting.

### 10.6.2. Vessel Breakaway

FSRU is equipped with Trelleborg QRHs which can be released manually under no load and up to their rated SWL, as well as remotely from Dockmaster station. All QRHs, in case of emergency, can be released within 90 seconds from Dockmaster station in FSRU CCR.

In case vessel breakaway the VSD cable link will trigger ESD followed with automatic sequence of releasing of all ERCs. This process is divided into 3 steps:

1. Alarm – notification to Operators
2. ESD 1 activation – stopping cargo machinery and closing ESD valves as per C&E for FSRU and LNGCC
3. ESD 2 – STS Hose's emergency disconnection by ERCs releasing. Each ERC is equipped with DVC valve (double closure, closing in 65ms) based on flip-flap method which allows instant closure and minimizing LNGC spillage. In this case STS Hose will remain on LNGCC side (manifold) while Fall Arrest System will manage the loads of the hoses to prevent any damage.

### 10.6.3. Incidents Onboard the LNGC Carrier

The LNGC is considered a self-contained unit, fully equipped to deal with major fires and other emergencies on board and capable of providing the initial response to most incidents.

The type of incident that can occur on board the LNGC berthed alongside the FSRU can in some instances have a significant impact on the integrity of the FSRU and the safety of its personnel.

Incidents with the potential to develop into a major event are:

- Fire/Explosion.
- Pollution through cargo and/or bunker fuel spills.
- Uncontrolled release of cargo vapour.

Other examples of incidents, which will require a response to minimize the outcome, or to avoid escalation into a significant event, are:

- Mechanical failure (affecting cargo operations).
- Man overboard.
- Accident (medical emergency).
- Failure of the carrier's moorings.

The following section deals with the specific immediate actions to be taken by the principal parties in the event of incidents. Subsequent actions to be taken will depend on how the incident develops and how well it is managed.

#### 10.6.3.1. Action by FSRU

- Initiate Emergency Shut Down; stop cargo operations.
- Implement Emergency Response Procedure.
- Start log of events.
- Tug (upon arrival/stand-by) to start fire pumps and assist as directed.
- Establish line of communications with LNGC Carrier.
- Coordinate with Port for marine resources and support.

#### 10.6.3.2. Action by LNGC with Emergency

- Initiate Emergency Shutdown Procedures: ensure all manifold(s) and tank valves are closed.
- Mobilize on board fire-fighting response.
- Establish communications with FSRU Control Room and advise nature & location of incident.
- Prepare to disconnect cargo hoses.

#### 10.6.3.3. Tugs & Pilots

- Tug (stand-by) to start fire pump and assist as directed by FSRU Master and/or Harbour Master.
- Duty Tug Masters to establish communications with Harbour Master.
- Remaining tugs to be mobilize and assist as directed.
- Prepare to remove the LNGC from the FSRU under direction of the STS Superintendent, Port Pilot, and agreement of Harbour Master.

#### 10.6.4. Steering, Main Engine or Power Failure on Approach

Should a failure occur during the approach phase this should be considered an emergency. If the LNGC is the fully functional Vessel, it should be manoeuvred to a safe distance.

The STS Superintendent will:

- Advise the Master to abort the approach.
- Inform and coordinate tugs.
- Manoeuvre the LNGC to a safe distance.
- Ensure that operations are not commenced until the issue is rectified, with any tests are carried out and written assurances are given to confirm this.

#### 10.6.5. Failure of Primary or Secondary Fenders on Approach

The STS Superintendent will:

- Advise the Master of the LNGC to abort the approach.
- Manoeuvre the Vessels to a safe distance apart.
- Inform and coordinate tugs.
- Adjust the heading control of the FSRU to place the remaining primary fenders in a lee.
- If possible, keep any loose fenders in sight and if not possible, try to estimate direction and rate of drift.
- Recover lost fender if possible.
- Ensure that operations are not resumed until the Vessels are correctly fendered.

#### 10.6.6. Failure of Primary or Secondary Fenders While Moored

##### 10.6.6.1. Action by FSRU

- Initiate emergency shutdown procedures: ensure all manifold(s) and tank valves are closed.
- Start log of events
- Inform the STS Superintendent.
- Inform and coordinate tugs, (upon arrival/stand-by), to be utilized to control the situation.
- Prepare and separate the Vessels under the guidance of the STS Superintendent.
- Adjust the heading control of the FSRU to place the remaining primary fenders in a lee.
- If possible, keep any loose fenders in sight and if not possible, try to estimate direction and rate of drift.
- Recover lost fender if possible.
- Ensure that operations are not resumed until the Vessels are correctly moored.

##### 10.6.6.2. Action by LNGC

- Initiate emergency shutdown procedures: ensure all manifold(s) and tank valves are closed.
- Start log of events.
- Inform the STS Superintendent.
- Prepare and separate the Vessels under the guidance of the STS Superintendent.

##### 10.6.6.3. Action by Tugs

- Tug prepares to stand by to assist.

#### 10.6.7. Failure of Mooring Lines

A single mooring line failure is an abnormal situation and should be assessed with the potential for multiple mooring line failure which escalates to an emergency situation.

##### **Single line failure**

##### 10.6.7.1. Action by FSRU

- Initiate controlled or emergency shutdown procedures: ensure all manifold(s) and tank valves are closed.
- Start log of events
- Inform the STS Superintendent.



- Inform and coordinate tugs, (upon arrival/stand-by), to be utilized to control the situation.
- Assess the situation to identify the cause of the mooring line failure.
- If this is expected to lead to multiple line failure, advise that this should be treated as an emergency and respond as per the multiple mooring line failure.
- If the situation is stable and no further lines are under significant stress or chance of parting, then the mooring line can be replaced.

#### 10.6.7.2. Action by LNGC

- Initiate controlled or emergency shutdown procedures: ensure all manifold(s) and tank valves are closed.
- Start log of events
- Inform the STS Superintendent.
- Assess the situation to identify the cause of the mooring line failure.
- If this is expected to lead to multiple line failure, advise that this should be treated as an emergency and respond as per the multiple mooring line failure.
- If the situation is stable and no further lines are under significant stress or chance of parting, then the mooring line can be replaced.

#### 10.6.7.3. Action by Tugs

- Tug prepares to stand by to assist.
- Confirm to Harbour Master and FSRU Control Room when standing by.
- Other tugs to prepare for standby to assist.

### **Multiple Mooring line Failure**

#### 10.6.7.4. Action by FSRU

- Initiate emergency shutdown procedures: ensure all manifold(s) and tank valves are closed.
- Start log of events.
- Inform the STS Superintendent.
- Disconnect hoses, either via Manual activation of ERC's or as per normal disconnection procedure should time permit.
- Inform and coordinate tugs, (upon arrival/stand-by), to be utilized to control the situation.
- Commence unmooring.

#### 10.6.7.5. Action by LNGC

- Initiate emergency shutdown procedures: ensure all manifold(s) and tank valves are closed.
- Start log of events.
- Inform the STS Superintendent.
- Disconnect hoses, either via Manual activation of ERC's or as per normal disconnection procedure should time permit.
- Commence manoeuvring the Vessels to minimize the loads on the remaining moorings.
- Commence unmooring, and manoeuvre LNGC clear of the FSRU.

#### 10.6.7.6. Action by Tugs

- Tug prepares to stand by to assist.
- Confirm to Harbour Master and FSRU Control Room when standing by.
- Other tugs to prepare for standby to assist.

#### 10.6.7.7. Action by FSRU

- Initiate emergency shutdown of cargo operations.
- Impose total smoking ban on board and secure all sources of ignition.
- Commence log of events.
- Isolate source of pollution and take whatever steps necessary to prevent or minimize further pollution.
- Initiate Oil Spill Response Procedure and Emergency Response.
- Initiate clean up if contained on board.
- Consult with appropriate authority to deploy adsorbent materials into the water.

#### 10.6.7.8. Action by LNGC

- Initiate emergency shutdown procedures ensure all manifold and tank valves are closed.
- Establish communications with FSRU CCR.
- Isolate source of pollution and take whatever steps necessary to prevent or minimize further pollution.
- Impose total smoking ban on board and secure all sources of ignition.
- Mobilize on board pollution response plan.
- Initiate clean up if contained on board.

#### 10.6.7.9. Action by Tugs

- Tug prepares to stand by to assist and stands off upwind until nature and type of spill has been established.
- Confirm to Harbour Master and FSRU Control Room when standing by.
- Other tugs to prepare for standby to assist.

### 10.6.8. Uncontrolled Release of LNGC/NG

#### 10.6.8.1. Action by FSRU

- Initiate emergency shut down on LNGC operation (if applicable)
- Impose total smoking ban on board and secure all sources of ignition.
- Commence log of events.
- Operate fire monitors if applicable.
- Initiate Emergency Response Plan.
- Establish communications with LNGC and advise nature and location of spill.

#### 10.6.8.2. Action by LNGC

- Initiate emergency shut down.

- Establish communications with FSRU and advise nature and location of spill.
- Impose total smoking ban on board and secure all sources of ignition.
- Mobilize ship emergency response plan.

#### 10.6.8.3. Action by Tugs & Pilot

- Stand-by tug to activate firefighting and deluge systems and stand well clear upwind and await instruction from FSRU.
- Secure all ignition sources and impose total smoking ban.
- Remaining tugs to mobilize and stand offshore.

#### 10.6.9. Hose Recovery Following ESD2 Event

After an emergency release of the hoses, LNGC is trapped between the closed ESD manifold valves and the split parts of the ERC's attached to each Vessel. Manifold pressure should be monitored on both Vessels and relieved to the cargo tanks. Cargo manifold and cargo line safety valves will release any excessive pressure back to ullage, but these should not be the primary path to trapped pressure in the hose.

The LNGC headers and cargo inventory should be drained back to tank following the normal end of cargo procedures.

Hull protection water curtain should be opened full flow and the water spray directed on the hoses to increase vaporization of the LNGC within. Careful attention to liquid manifold pressure is necessary to avoid vaporization creating high internal pressures.

A continuous water spray by means of the wash down hoses should be directed on the hoses in order to accelerate the evaporation rate of the LNGC trapped inside the hoses. This will increase the pressure in the hoses, the manifold ESD and bypass valves should be opened to avoid over-pressurization.

The hoses can be confirmed liquid free when icing is no longer present on the ERC coupling at the end of the hose and the hose pressure does not increase when the manifold valves are closed.

Purging of the STS hoses connected to the vapor manifold should already be started during liquid freeing of the hoses which are connected to the liquid manifold(s).

Once the liquid transfer hoses are liquid free, nitrogen pressurizing of the liquid manifolds commences. Pressure inside the hoses will be raised up to 4 – 5 bar and is released to the cargo tanks.

Purging of the STS hoses after an emergency release is expected to take a considerable amount of time, as nitrogen is introduced and released on the same side of the hose only dilution of the atmosphere inside the hose occurs.

Regular readings of LEL should be taken to monitor the purging progress. Operational guidelines define purging to be completed once < 2% by volume is achieved.

The STS hoses should be disconnected from the LNGC manifold and temporarily stowed on the deck. Care should be taken to protect the ERC male half from damage.

The Fall arrest ropes attached to each male side of the ERC can be removed as the hose is recovered and it becomes accessible.

The parted Drift alarm, ESD1 and ESD2 cables should be recovered by hand.

In a post ESD-2 recovery operation, the causal factors to the initiating event will generally direct the method of returning the STS equipment from the LNGC to the ALEXANDROUPOLIS or onshore. This could be directly between the Vessels if the Vessels return alongside each other or by a launch/LSV.

Coordination of suitable transport boxes for the cargo hoses, ERC half and associated equipment from the ALEXANDROUPOLIS can be arranged depending on the cause of the ESD-2.

#### 10.6.10. Security Breach

During interface, the Port Facility Security Plan within the exclusion zone applies. Any Security incidents on the LNG/C should be reported to the Port Facility Security and to FSRU security Officer with all ISPS Code related items in accordance with FSRU ALEXANDROUPOLIS ISPS manual requirements.

### 10.7. Incident Reporting

The response to any incident will depend on the nature, location, and severity of the event. The FSRU Terminal and the LNGC must be directed by their respective Emergency Response Plans. The following contains bulleted immediate actions which are to be taken by the principal parties.

If marine craft are required to approach or go alongside the LNGC Vessel concerned, they may only do so after the FSRU Terminal OIM has confirmed that loading operations have been stopped.

Any incident/accident or event that falls under the following categories is subject to a full incident investigation:

- Marine incident (collision, grounding, allision)
- PSC detention or customer rejections
- Drug & Alcohol policy breach
- Security breach due to either cyber or physical attack
- Loss of primary containment/venting or spill whether contained or in water
- Loss of propulsion or loss of steering
- LTI or serious injuries, death(s) ashore or onboard
- Delay or significant event relating to the New Buildings/approved Projects
- Off-hire whether planned or unplanned
- Breakdown or claim made against GasLog
- Any event with publicity that may have a significant detrimental effect on the name/standing of GasLog with or without any financial impact. The latter is not subject to a financial threshold (for example any event constituting a criminal offense, breach of the Code of Business Conduct, the Antitrust Policy, ABC Policy, or whistleblower line notification).

FSRU Terminal OIM is in overall charge of any incident at Terminal.

The involved vessels should forward the results of the Incidents investigation to GAS TRADE S.A for their consideration and information.

# 11. References

Ship to Ship Transfer Guide for Petroleum, Chemicals and Liquefied Gases (OCIMF)(SIGTTO)(CDI)(ICS), First Edition 2013

Liquefied Gas Handling Principles on Ships and in Terminals 4<sup>th</sup> Edition (SIGTTO), 2016

The International Code for the Construction and Equipment of Ship Carrying Liquefied Gases in Bulk (IGC Code) (IMO)

Standard Marine Communication Phrases (IMO)

International Convention for the Prevention of Collisions at Sea (COLREGS 72).

Guidelines for the Handling, Storage, Use, Maintenance and Testing of STS hoses (OCIMF), 2021

Marine Terminal Information Booklet, Guidelines and Recommendations (OCIMF), First Edition 2018

Commercial and Operation Manual, GASLOG

Port regulations, FEK B-6355-2023, Government of Greece

STS service provider management and self-assessment: a best practice guide 2<sup>nd</sup> Edition, (OCIMF), 2020

# APPENDICES

1. Location Assessment
2. ISGOTT Ship shore Checklist
3. Fender Certificates
4. Hose Certificates
5. Proposed Mooring Plan
6. Fender Mooring Arrangement Plan

## 1. Location Assessment



# STS Assessment Location

**FSRU ALEXANDROUPOLIS – DRAFT (Not for Release)**

January 2024

Version 1.00

For GAS TRADE S.A.



This Page is intentionally left blank



# Report on

## Location Assessment

### Offshore Alexandroupolis

---

---



## Disclaimer

This report is a location assessment for the anchored area of the Offshore Alexandroupolis.

The views, thoughts, and opinions expressed in this report belong solely to the author(s) for and behalf of DYNAMARINE and are based on the facts and data conveyed by the clients through best industry practices, with reference to OCIMF STS Transfer Guidelines and the STS Service Provider Management and Self-Assessment, Second edition 2020.

The author(s) do not make any warranties about the completeness of the information conveyed in this report. Any action you take regarding the information in this report is strictly at the users' own risk, and DYNAMARINE will not be liable for any losses and damages in connection with the use of this report.

DYNAMARINE© January 2024, Contact: [info@dynamarine.com](mailto:info@dynamarine.com)

Version: 1.00

ISBN: N/A

DYNAMARINE is a member of



And has received accreditations for their STS services from LR and ABS



## Table of Contents

Table of Contents.....	6
1. Introduction .....	7
2. Location Analysis.....	8
Exclusion Zone .....	9
Restricted Areas and Security Zones .....	10
Time .....	10
Port and Harbor authorities.....	10
3. Weather Assessment .....	11
FSRU Offshore Alexandroupolis.....	11
4. Appendix .....	12
STS Location Assessment Matrix .....	12
Weather Data Analysis.....	16
Offshore Alexandroupolis .....	16

## 1. Introduction

The objective of Location Assessment is to review all available information for a specific location and identify potential risks.

In addition, the STS organizer should exercise due diligence, prior organizing an STS operation at the respective STS location, to establish safeguards for the potential STS risks of the STS area. The STS organizer should also ensure that the nominated STS service providers have all the necessary resources, at shore and at sea, to assist Masters in performing a safe STS operation. STS Service Providers, as well as STS superintendents, are considered vital elements in ensuring safety.

Notwithstanding the assessment performed, technical operators and, more specifically Masters, are responsible to ensure the safety of the STS operations and they “... shall under no circumstances permit safety to be jeopardized by the actions of others.” [2013 edition of OCIMF guidelines, paragraph 1.5.1].

In this report, the location of offshore FSRU ALEXANDROUPOLIS is reviewed. The following sources were utilized:

- **Historical Weather data provided by Storm Glass**
- **Navionics.com**
- **British Admiralty Nautical Chart 1086**
- **British Admiralty Nautical Chart 1636**
- **Operation Marine Manual of FSRU ALEXANDROUPOLIS**
- **Ship to Ship Service Provider Management and Self-Assessment, 2<sup>nd</sup> Edition**

This report has been developed and designed on behalf of GAS TRADE S.A.

## 2. Location Analysis

For the purpose of this report, one area within the general region of Alexandroupolis has been examined. FSRU ALEXANDROUPOLIS is stationed 17.6km Southwest from the port Alexandroupolis and 10 km from the nearest coast of Makri. The approx. water depth is 40m.

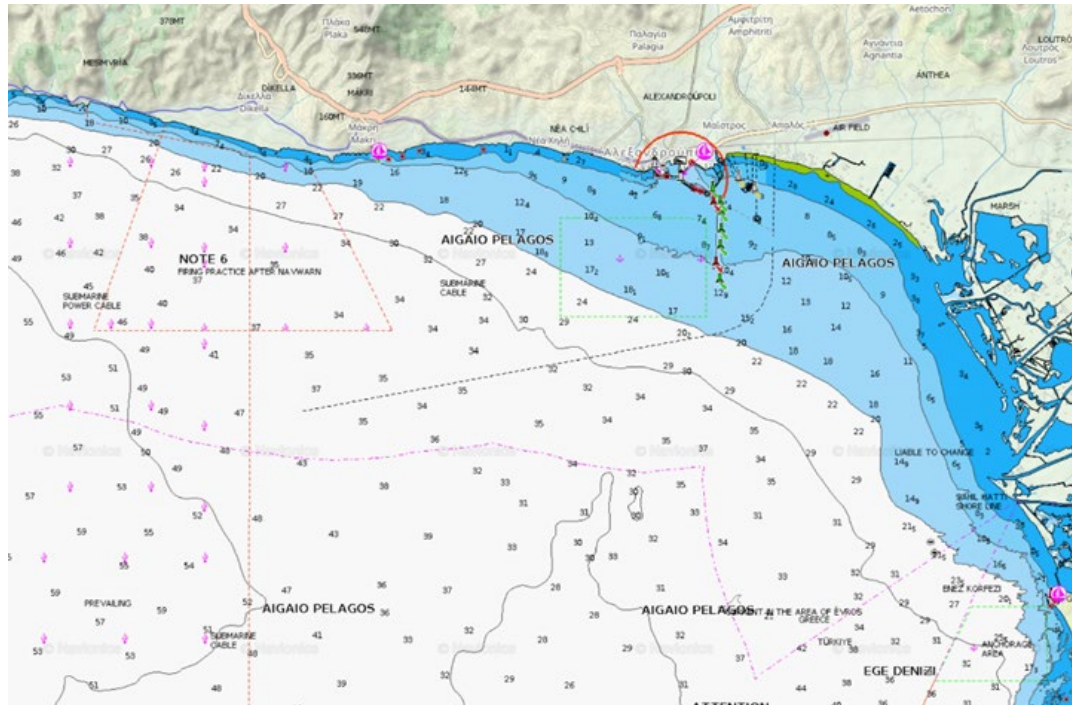

Figure 1 Location Nautical Chart

The FSRU ALEXANDROUPOLIS is orientated on a heading of 205 N (SSW) and held in position by a restricted catenary mooring (RCM) system, or spread mooring system, where four set of three mooring lines are deployed.

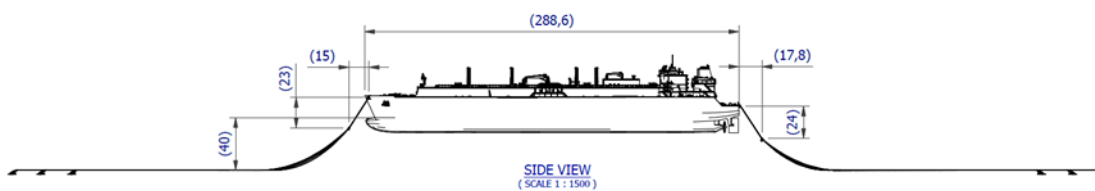

Figure 2 Anchoring Plan - Side View

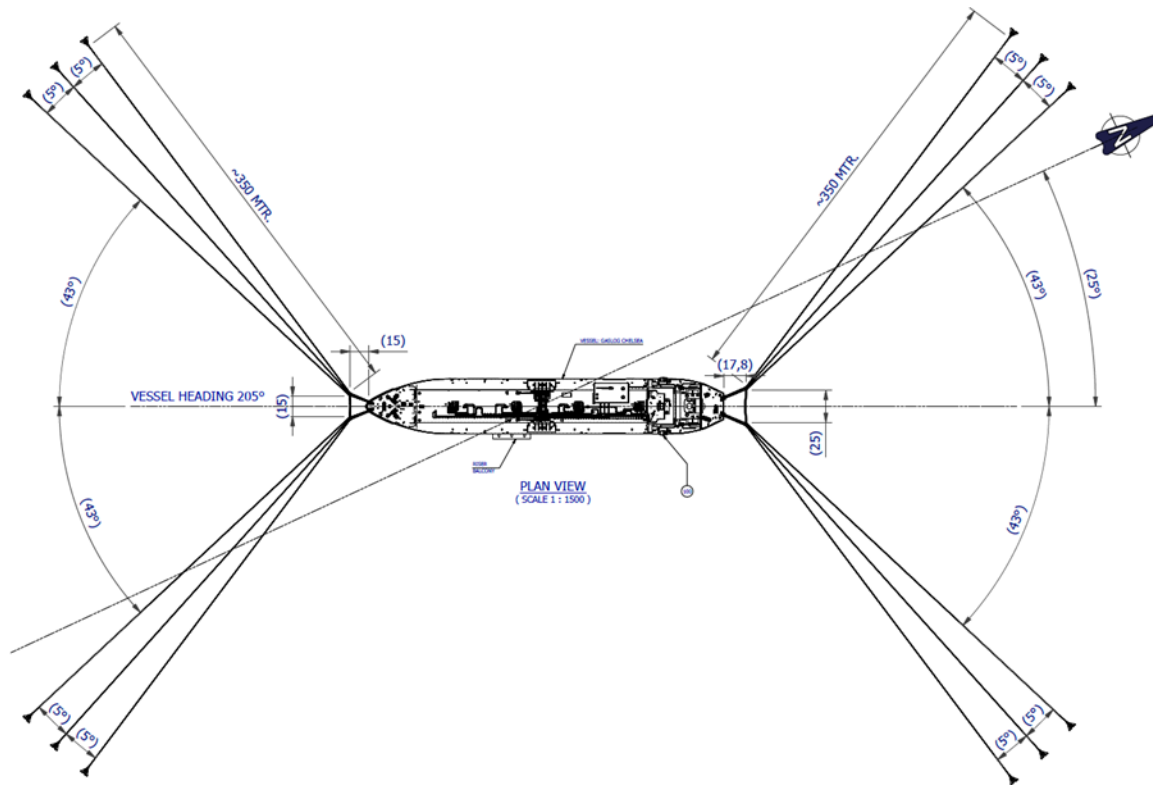

Figure 3 Anchoring Plan - Plan View

### Exclusion Zone

The exclusion zone expands 500m outside the (blue) circular area including the mooring lines of the spread mooring and the FSRU (cyan circular area).

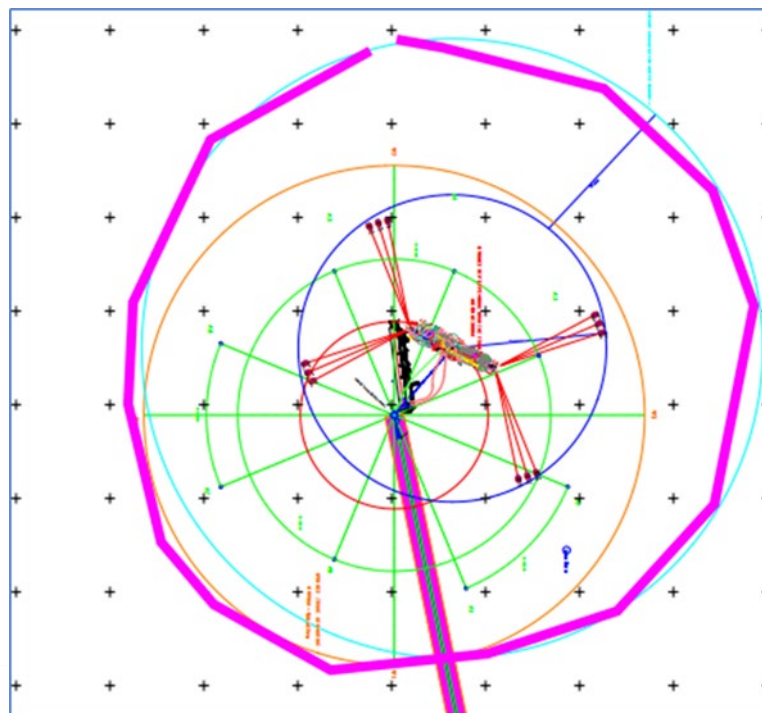

Figure 4 Exclusion Zone, Source commercial terminal operation's manual



### Restricted Areas and Security Zones

Access to the Restricted Area is exclusively for LNG Vessels calling at the FSRU Terminal, mooring and service support vessels, either working for or authorized by the FSRU Terminal and Local Authorities, as well as those vessels associated with law enforcement agencies.

The FRSU Terminal operates at Security Level 1, however all security related questions should be addressed to the FRSU Terminal Representative and/or FSRU Master.

Any security incidents on board the FSRU ALEXANDROUPOLIS must be reported to the ALEXANDROUPOLIS Port Control with all ISPS Code related items in accordance with the ALEXANDROUPOLIS ISPS Manual requirements.

### Time

FRSU ALEXANDROUPOLIS operates at Greece Time, EET (Eastern European Time).

Summer time: UTC/GMT +3 hours

Winter Time: UTC/GMT +2 hours

### Port and Harbor authorities

The location of the offshore FSRU ALEXANDROUPOLIS is under the Alexandroupolis Port Authority. However, STS operations are conducted Off Port Limits without interfering with local marine traffic routes. The involvement of a local Pilots is required during the conduction of the STS operation.

### 3. Weather Assessment

Weather data have been examined for the duration of the last 5 years (Starting January 1<sup>st</sup>, 2019, to January 8<sup>th</sup>, 2024). Details charts for the below Weather Data can be found at the Appendix of this report.

#### FSRU Offshore Alexandroupolis

The most important observations regarding the weather characteristics at Offshore Alexandroupolis can be found below.

<b>Wave Height</b>	The most frequent Wave Height was up to 0,4m and rarely exceeded waves of more than 1,6m.
<b>Wave Period</b>	Wave period was usually around 1,2s to 3,6s.
<b>Wave Direction</b>	Wave Direction was calculated to be from 0 to 225 degrees meaning North to Southwest.
<b>Swell Height</b>	The most frequent Swell Height was calculated between 0,2m and 0,4m. In very rare cases values exceed 0,8m.
<b>Swell Period</b>	Swell Period was frequently between 1,2s to 6,0s. In a few cases reached and did not exceed the 11,0s. while the average was around 3,0s.
<b>Swell Direction</b>	Swell direction was also calculated to be from the Northeast to Southwest.
<b>Wind Speed</b>	Average Wind Speed was only around 7,8 knots and rarely exceeded 16,0 knots.
<b>Wind Direction</b>	Wind Direction was also calculated to be mainly from the North - Northeast side and in a few cases from the Southwest.

#### Summary

Weather conditions are generally suitable for STS operations. Offshore Alexandroupolis is an area that is mostly affected by Waves and Swell. The effect of Wind is relatively small (7,8 knots) as the wind speed rarely exceeds 16,0 knots. Attention is drawn with respect to the swell period, usually more than 11s and only when combined with a swell height of more than 1m which could present a challenge in vessels of smaller size. However, the same is subject to on-site assessment. Swell, Wave and Wind Direction are consistently from the Northeast while Wind Direction is also frequent from the West.

---

## 4. Appendix

### STS Location Assessment Matrix

Location name	Offshore Alexandroupolis	
Location	Lat: 40.76 N	Long: 25.71 E
Contiguous Coastal States	Alexandroupolis Port Authority	

Item/Question		Criteria	Remarks
1	Do available service providers require authorization for STS operations?	Providers to be approved	Not Applicable
2	Is the location under the control of port and harbor authorities?	For information	YES, Under Alexandroupolis Port Authority
3	Is the location under the control of a Coastal State?	For information	YES, Under Alexandroupolis Port Authority
4	Is the location used frequently for STS operations?	For information	N/A
5	Are appropriate charts available for the STS operation area?	Appropriate Charts should be available, otherwise other valid source of information is required.	<p>The position of the terminal is recorded on the nautical charts and publications after the completion of its installation and related clearance by the Administrator/Manager and the Maritime Authority/Hellenic Coast Guard to the Hellenic Navy Hydrographic Service, as follows:</p> <ul style="list-style-type: none"> <li>• Nautical Charts &amp; Publications of the Hellenic Navy Hydrographic Service (HNHS): XEE-109, 2, 4, 41, 42, 43, 47, 32, 33, 322, 3221, 322/1</li> </ul> <p>Corresponding charts are also issued by the British Admiralty. Covering requirements from the above Agencies for electronic maps (ECDIS) as well.</p> <ul style="list-style-type: none"> <li>• British Admiralty Nautical Chart 1086</li> <li>• British Admiralty Nautical Chart 1636</li> </ul>
6	Does the proximity of the STS location cause hazard to other marine traffic routes and is it safe for STS operations?	Possible hazards to be evaluated.	There FSRU Anchorage area is clear of any marine routes and in safe distance from the Alexandroupolis Anchorage Area.

7	Is the STS location sheltered from the open sea? What are the recommended maximum weather criteria?	Weather criteria should be established from authorities as the STS location is under development.	The area is generally open, however from the south, there is a certain amount of wave sheltering from the outer islands.  For Weather Limitations, please refer to Terminal Operation Manual.
8	Is there adequate space for safe STS operations?	In case of limited space, only at anchor mooring operations should have to take place.	Yes, please refer to Terminal Operation Manual.
9	What is the preferred choice of maneuver at this location?	For information	<i>LNGC will maneuver alongside the STBD Side of the FSRU. The maneuvering plan will be subject to assessment upon embarkation of the Pilot, taking into consideration the prevailing weather conditions.</i>  <i>Please refer to the Joint Plan of Operations.</i>
10	Is the location suitable for anchoring?	For information	Yes
11	Is the STS location situated in adequate depth?	For information	Yes, Approximate depth at FSRU Anchorage area about 39m.
12	Is the STS location suitable for STS mooring operations?	Predominant weather conditions and depth should allow for mooring operations	Yes, Weather conditions are generally suitable for Mooring Operations.
13	Are there any restrictive met ocean conditions in selecting the location?	Met ocean conditions to be applicable for the STS gear and approved for the STS Service Provider or the administration.	Area generally suitable for operations
14	Is the STS location covered by an adequate weather forecasting service?	If the answer is negative, no STS operation can take place.	Yes, Weather forecasting available from various Weather Forecasts provider
15	Is tidal height and tidal stream data available for the location?	If the answer is negative, no STS operations can take place.	Yes, Available from various sources.
16	STS location area to be checked for security level and details provided of port security level.	Vessels should be able to be timely informed.	No special security requirements are applicable in the area by the local authorities. FSRU is operating at security level 1. An exclusion zone of 500m (radius) expands around the FSRU Anchorage location.

17	How do the service providers assess security level of operation?	Service providers should have efficient access to this information.	N/A, FSRU is operating at security level 1.
18	Have the service providers ensured that the area for STS is covered by an approved spill response organization?	Approved spill response organization details should be available.	In case of incident, Facility Operator procedures and the Facility Contingency Plan (FCP) shall be followed.
19	Are there any particular local or national STS regulations that are to be complied with during STS operation?	STS operations to comply with local regulations	Yes, "ANCHORAGE FEK B-06355-2023"
20	Are there any physical limitations on vessel size (draught, length, freeboard, etc.) at the location?	Depending on the participating vessel size	Berth Approval Parameters as per the Terminal Operation Manual.  Any deviations from such figures will be examined on a case-by-case basis and risk assessment.
21	Provide a brief description of the STS location, availability of services, transit times ashore, service boats and any other comments appropriate to assist in determining the suitability of the location for STS operation.	Criteria to be defined on a case-by-case occasion and subject to scope of business	The FSRU will be stationed in the sea of Thrace, 17.6 km SW of Alexandroupolis, at an offshore distance of 10 km from the nearest shore (within Territorial waters - 6 nautical miles). The FSRU will be in approximately 40 m water depth.
22	Number, type and bollard pull of tugs available at the location.	For mooring operations at anchor, tug availability should be reviewed in conjunction with participating vessel size.	The tugs selected for supporting the berthing/unberthing procedures of the LNG Carriers to the FSRU are typically of azimuth stern drive type (ASD) tugs of about 28 m length, 13 m beam, 5 m depth, draught of around 5 m, speed of 12.5 knots and a bollard pull of 80-85 tons.

23	Is the available STS gear at the transfer area according to requirements and standards?	<ul style="list-style-type: none"> <li>• Fender requirements according to OCIMF and international standard certification</li> <li>• In case the vessel is equipped with permanent fenders and hoses, there shall be procedures in place to monitor and assess the condition of such equipment in accordance with manufacturer guidelines.</li> </ul>	<p>Relevant gear to be provided by the FSRU ALEXANDROUPOLIS.</p> <p>Please refer to Terminal Operation Manual.</p>
24	Are support vessels under in the operation inspected and certificated under local/national legislation?	<p>Uncertified Support vessels should not be accepted.</p> <p>Support vessel details to be submitted for review.</p>	<p>Yes, in line with local requirements.</p>
25	Does the Service Provider send advance STS instructions to the ship? Information sent out should be in accordance with the latest edition of industry STS guidelines.		<p>YES, FSRU ALEXANDROUPOLIS to share any required information to the visiting LNGCs.</p>
26	In the particular location, what is the normal mode of personnel transfer?	<p>PTB transfers to be conducted as per OCIMF "Transfer of Personnel by Crane between Vessels" 2018 publication</p>	<p>Personnel transfer between FSRU and LNGCs to be conducted through Personnel Transfer Basket.</p>
27	If the STS is within port limits, are harbor pilots used for STS maneuvering? If so, what STS experience/training do they have?	<p>Inexperienced Pilots should not be employed.</p> <p>Pilot experience to be reviewed, if available.</p>	<p>Yes, Harbor Pilots used for LNGC maneuvering. Pilots have received relevant Simulator training which took place in December 2023.</p>

## Weather Data Analysis

### Offshore Alexandroupolis

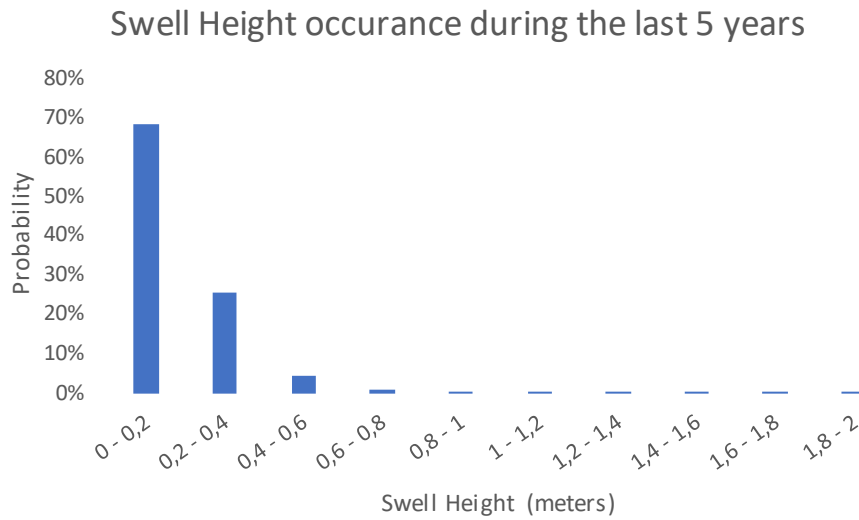

Figure 5 Swell Height – Offshore Alexandroupolis

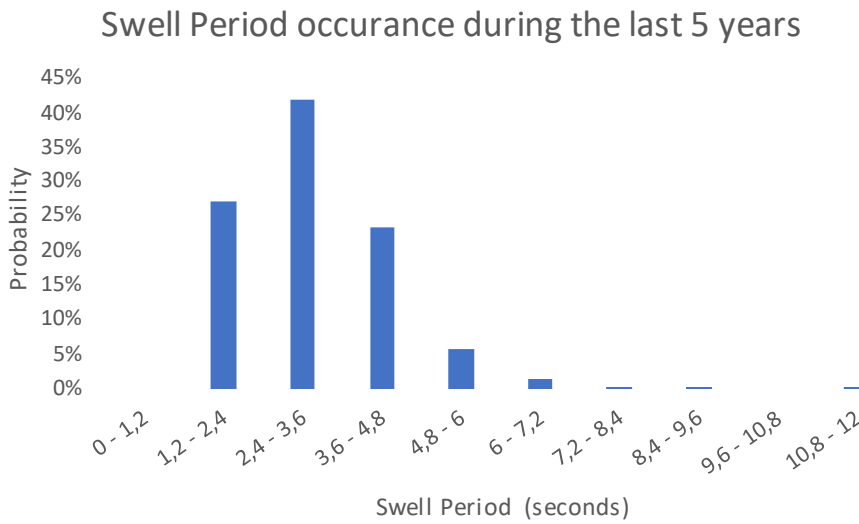

Figure 6 Swell Period - Offshore Alexandroupolis

### Swell Direction occurrence during the last 5 years

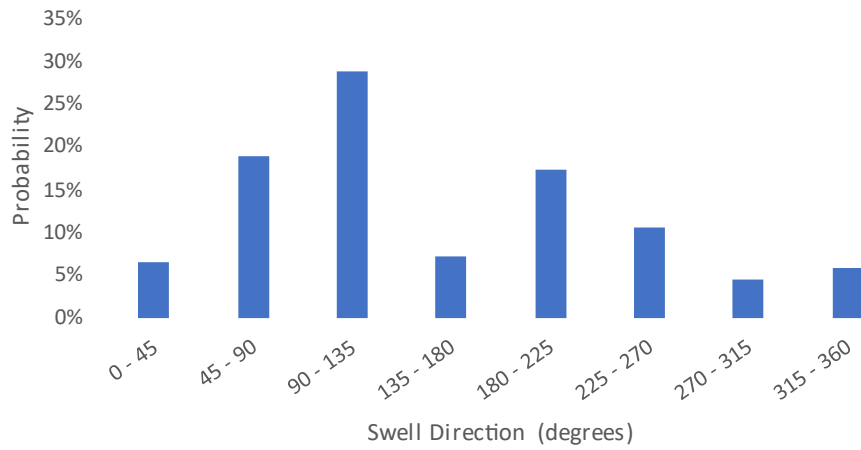

Figure 7 Swell Direction - Offshore Alexandroupolis

### Wave Height occurrence during the last 5 years

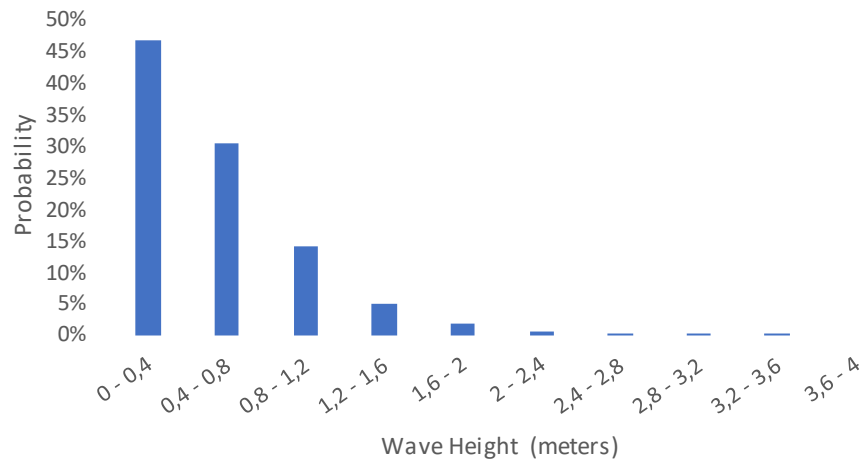

Figure 8 Wave Height – Offshore Alexandroupolis



### Wave Period occurrence during the last 5 years

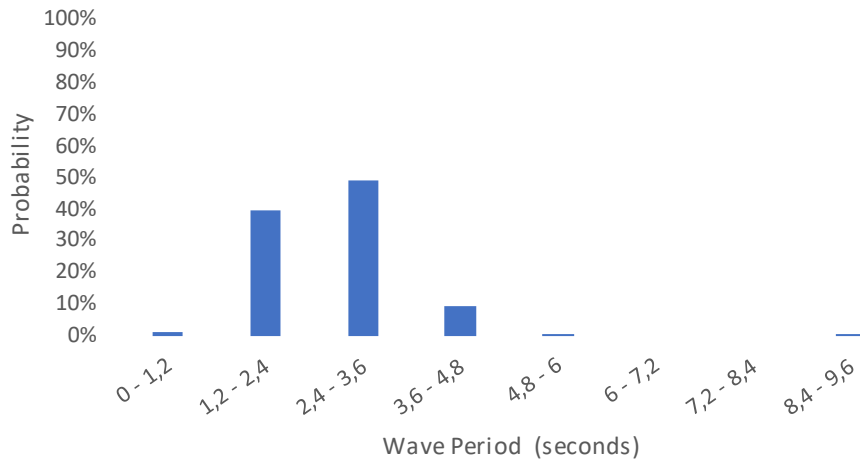

Figure 9 Wave Period - Offshore Alexandroupolis

### Wave Direction occurrence during the last 5 years

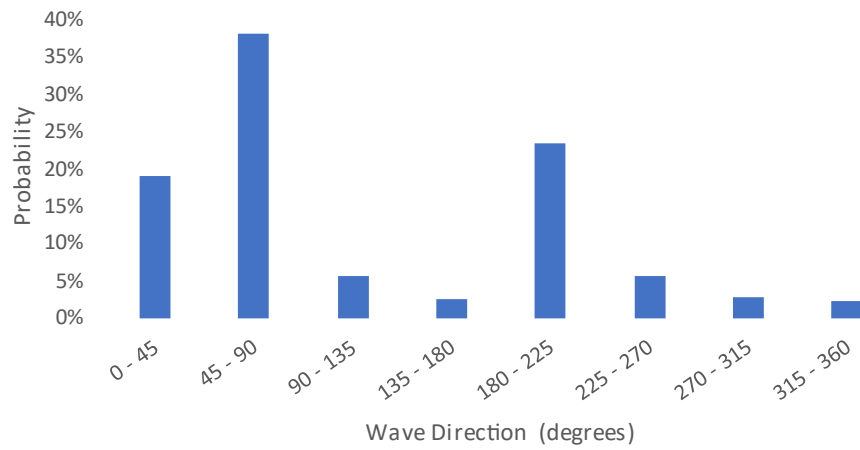

Figure 10 Wave Direction - Offshore Alexandroupolis

### Wind Speed occurrence during the last 5 years

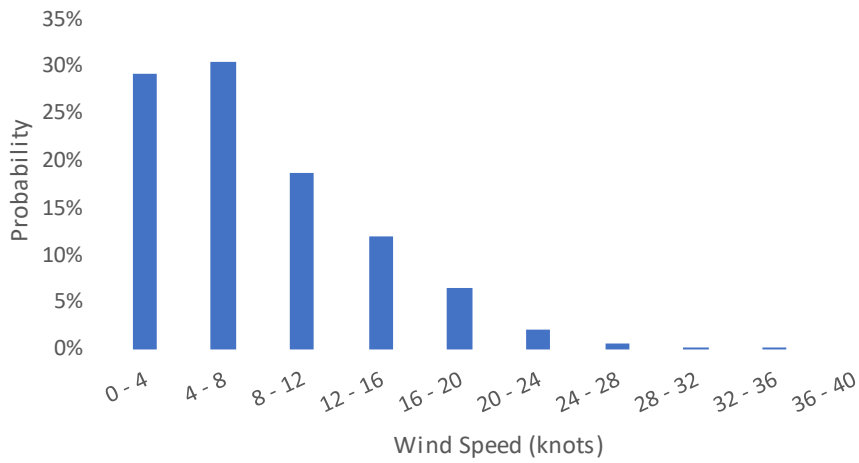

Figure 11 Wind Speed – Offshore Alexandroupolis

### Wind Direction occurrence during the last 5 years

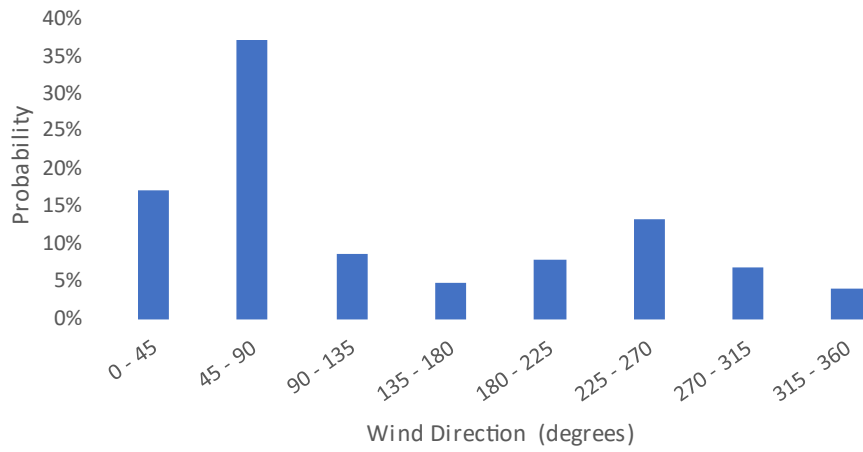

Figure 12 Wind Direction - Offshore Alexandroupolis

This Page is intentionally left blank

---

2 Arkadias Str. D. Gounari 125  
Glyfada 16561, GR

Tel: (+30) 210 9628379 (+30) 210  
8941667

Email: [info@dynamarine.com](mailto:info@dynamarine.com)  
[www.dynamarine.com](http://www.dynamarine.com)



## 2. ISGOTT Ship shore Checklist

## ISGOTT Checks pre-arrival Ship/Shore Safety Checklist

Date and time: \_\_\_\_\_

Port and berth: \_\_\_\_\_

Tanker: \_\_\_\_\_

Terminal: \_\_\_\_\_

Product to be transferred: \_\_\_\_\_

Part 1A. Tanker: checks pre-arrival			
Item	Check	Status	Remarks
1	Pre-arrival information is exchanged (6.5, 21.2)	<input type="checkbox"/> Yes	
2	International shore fire connection is available (5.5, 19.4.3.1)	<input type="checkbox"/> Yes	
3	Transfer hoses are of suitable construction (18.2)	<input type="checkbox"/> Yes	
4	Terminal information booklet reviewed (15.2.2)	<input type="checkbox"/> Yes	
5	Pre-berthing information is exchanged (21.3, 22.3)	<input type="checkbox"/> Yes	
6	Pressure/vacuum valves and/or high velocity vents are operational (11.1.8)	<input type="checkbox"/> Yes	
7	Fixed and portable oxygen analysers are operational (2.4)	<input type="checkbox"/> Yes	

Part 1B. Tanker: checks pre-arrival if using an inert gas system			
Item	Check	Status	Remarks
8	Inert gas system pressure and oxygen recorders are operational (11.1.5.2, 11.1.11)	<input type="checkbox"/> Yes	
9	Inert gas system and associated equipment are operational (11.1.5.2, 11.1.11)	<input type="checkbox"/> Yes	
10	Cargo tank atmospheres' oxygen content is less than 8% (11.1.3)	<input type="checkbox"/> Yes	
11	Cargo tank atmospheres are at positive pressure (11.1.3)	<input type="checkbox"/> Yes	

Part 2. Terminal: checks pre-arrival			
Item	Check	Status	Remarks
12	Pre-arrival information is exchanged (6.5, 21.2)	<input type="checkbox"/> Yes	
13	International shore fire connection is available (5.5, 19.4.3.1, 19.4.3.5)	<input type="checkbox"/> Yes	
14	Transfer equipment is of suitable construction (18.1, 18.2)	<input type="checkbox"/> Yes	
15	Terminal information booklet transmitted to tanker (15.2.2)	<input type="checkbox"/> Yes	
16	Pre-berthing information is exchanged (21.3, 22.3)	<input type="checkbox"/> Yes	

## ISGOTT Checks after mooring Ship/Shore Safety Checklist

Part 3. Tanker: checks after mooring			
Item	Check	Status	Remarks
17	Fendering is effective (22.4.1)	<input type="checkbox"/> Yes	
18	Mooring arrangement is effective (22.2, 22.4.3)	<input type="checkbox"/> Yes	
19	Access to and from the tanker is safe (16.4)	<input type="checkbox"/> Yes	
20	Scuppers and savealls are plugged (23.7.4, 23.7.5)	<input type="checkbox"/> Yes	
21	Cargo system sea connections and overboard discharges are secured (23.7.3)	<input type="checkbox"/> Yes	
22	Very high frequency and ultra high frequency transceivers are set to low power mode (4.11.6, 4.13.2.2)	<input type="checkbox"/> Yes	
23	External openings in superstructures are controlled (23.1)	<input type="checkbox"/> Yes	
24	Pumproom ventilation is effective (10.12.2)	<input type="checkbox"/> Yes	
25	Medium frequency/high frequency radio antennae are isolated (4.11.4, 4.13.2.1)	<input type="checkbox"/> Yes	
26	Accommodation spaces are at positive pressure (23.2)	<input type="checkbox"/> Yes	
27	Fire control plans are readily available (9.11.2.5)	<input type="checkbox"/> Yes	

Part 4. Terminal: checks after mooring			
Item	Check	Status	Remarks
28	Fendering is effective (22.4.1)	<input type="checkbox"/> Yes	
29	Tanker is moored according to the terminal mooring plan (22.2, 22.4.3)	<input type="checkbox"/> Yes	
30	Access to and from the terminal is safe (16.4)	<input type="checkbox"/> Yes	
31	Spill containment and sumps are secure (18.4.2, 18.4.3, 23.7.4, 23.7.5)	<input type="checkbox"/> Yes	



## ISGOTT Checks pre-transfer Ship/Shore Safety Checklist

Date and time: \_\_\_\_\_

Port and berth: \_\_\_\_\_

Tanker: \_\_\_\_\_

Terminal: \_\_\_\_\_

Product to be transferred: \_\_\_\_\_

Part 5A. Tanker and terminal: pre-transfer conference				
Item	Check	Tanker status	Terminal status	Remarks
32	Tanker is ready to move at agreed notice period (9.11, 21.7.1.1, 22.5.4)	<input type="checkbox"/> Yes	<input type="checkbox"/> Yes	
33	Effective tanker and terminal communications are established (21.1.1, 21.1.2)	<input type="checkbox"/> Yes	<input type="checkbox"/> Yes	
34	Transfer equipment is in safe condition (isolated, drained and de-pressurised) (18.4.1)	<input type="checkbox"/> Yes	<input type="checkbox"/> Yes	
35	Operation supervision and watchkeeping is adequate (7.9, 23.11)	<input type="checkbox"/> Yes	<input type="checkbox"/> Yes	
36	There are sufficient personnel to deal with an emergency (9.11.2.2, 23.11)	<input type="checkbox"/> Yes	<input type="checkbox"/> Yes	
37	Smoking restrictions and designated smoking areas are established (4.10, 23.10)	<input type="checkbox"/> Yes	<input type="checkbox"/> Yes	
38	Naked light restrictions are established (4.10.1)	<input type="checkbox"/> Yes	<input type="checkbox"/> Yes	
39	Control of electrical and electronic devices is agreed (4.11, 4.12)	<input type="checkbox"/> Yes	<input type="checkbox"/> Yes	
40	Means of emergency escape from both tanker and terminal are established (20.5)	<input type="checkbox"/> Yes	<input type="checkbox"/> Yes	
41	Firefighting equipment is ready for use (5, 19.4, 23.8)	<input type="checkbox"/> Yes	<input type="checkbox"/> Yes	
42	Oil spill clean-up material is available (20.4)	<input type="checkbox"/> Yes	<input type="checkbox"/> Yes	
43	Manifolds are properly connected (23.6.1)	<input type="checkbox"/> Yes	<input type="checkbox"/> Yes	
44	Sampling and gauging protocols are agreed (23.5.3.2, 23.7.7.5)	<input type="checkbox"/> Yes	<input type="checkbox"/> Yes	
45	Procedures for cargo, bunkers and ballast handling operations are agreed (21.4, 21.5, 21.6)	<input type="checkbox"/> Yes	<input type="checkbox"/> Yes	
46	Cargo transfer management controls are agreed (12.1)	<input type="checkbox"/> Yes	<input type="checkbox"/> Yes	
47	Cargo tank cleaning requirements, including crude oil washing, are agreed (12.3, 12.5, 21.4.1)	<input type="checkbox"/> Yes	<input type="checkbox"/> Yes	See also parts 7B/7C as applicable

Part 5A. Tanker and terminal: pre-transfer conference (cont.)				
Item	Check	Tanker status	Terminal status	Remarks
48	Cargo tank gas freeing arrangements agreed (12.4)	<input type="checkbox"/> Yes	<input type="checkbox"/> Yes	See also part 7C
49	Cargo and bunker slop handling requirements agreed (12.1, 21.2, 21.4)	<input type="checkbox"/> Yes	<input type="checkbox"/> Yes	See also part 7C
50	Routine for regular checks on cargo transferred are agreed (23.7.2)	<input type="checkbox"/> Yes	<input type="checkbox"/> Yes	
51	Emergency signals and shutdown procedures are agreed (12.1.6.3, 18.5, 21.1.2)	<input type="checkbox"/> Yes	<input type="checkbox"/> Yes	
52	Safety data sheets are available (1.4.4, 20.1, 21.4)	<input type="checkbox"/> Yes	<input type="checkbox"/> Yes	
53	Hazardous properties of the products to be transferred are discussed (1.2, 1.4)	<input type="checkbox"/> Yes	<input type="checkbox"/> Yes	
54	Electrical insulation of the tanker/terminal interface is effective (12.9.5, 17.4, 18.2.14)	<input type="checkbox"/> Yes	<input type="checkbox"/> Yes	
55	Tank venting system and closed operation procedures are agreed (11.3.3.1, 21.4, 21.5, 23.3.3)	<input type="checkbox"/> Yes	<input type="checkbox"/> Yes	
56	Vapour return line operational parameters are agreed (11.5, 18.3, 23.7.7)	<input type="checkbox"/> Yes	<input type="checkbox"/> Yes	
57	Measures to avoid back-filling are agreed (12.1.13.7)	<input type="checkbox"/> Yes	<input type="checkbox"/> Yes	
58	Status of unused cargo and bunker connections is satisfactory (23.7.1, 23.7.6)	<input type="checkbox"/> Yes	<input type="checkbox"/> Yes	
59	Portable very high frequency and ultra high frequency radios are intrinsically safe (4.12.4, 21.1.1)	<input type="checkbox"/> Yes	<input type="checkbox"/> Yes	
60	Procedures for receiving nitrogen from terminal to cargo tank are agreed (12.1.14.8)	<input type="checkbox"/> Yes	<input type="checkbox"/> Yes	

#### Additional for chemical tankers      Checks pre-transfer

Part 5B. Tanker and terminal: bulk liquid chemicals. Checks pre-transfer				
Item	Check	Tanker status	Terminal status	Remarks
61	Inhibition certificate received (if required) from manufacturer	<input type="checkbox"/> Yes	<input type="checkbox"/> Yes	
62	Appropriate personal protective equipment identified and available (4.8.1)	<input type="checkbox"/> Yes	<input type="checkbox"/> Yes	
63	Countermeasures against personal contact with cargo are agreed (1.4)	<input type="checkbox"/> Yes	<input type="checkbox"/> Yes	
64	Cargo handling rate and relationship with valve closure times and automatic shutdown systems is agreed (16.8, 21.4, 21.5, 21.6)	<input type="checkbox"/> Yes	<input type="checkbox"/> Yes	
65	Cargo system gauge operation and alarm set points are confirmed (12.1.6.6.1)	<input type="checkbox"/> Yes	<input type="checkbox"/> Yes	

**Part 5B. Tanker and terminal: bulk liquid chemicals. Checks pre-transfer (cont.)**

Item	Check	Tanker status	Terminal status	Remarks
66	Adequate portable vapour detection instruments are in use (2.4)	<input type="checkbox"/> Yes	<input type="checkbox"/> Yes	
67	Information on firefighting media and procedures is exchanged (5, 19)	<input type="checkbox"/> Yes	<input type="checkbox"/> Yes	
68	Transfer hoses confirmed suitable for the product being handled (18.2)	<input type="checkbox"/> Yes	<input type="checkbox"/> Yes	
69	Confirm cargo handling is only by a permanent installed pipeline system	<input type="checkbox"/> Yes	<input type="checkbox"/> Yes	
70	Procedures are in place to receive nitrogen from the terminal for inerting or purging (12.1.14.8)	<input type="checkbox"/> Yes	<input type="checkbox"/> Yes	

**Additional for gas tankers Checks pre-transfer****Part 5C. Tanker and terminal: liquefied gas. Checks pre-transfer**

Item	Check	Tanker status	Terminal status	Remarks
71	Inhibition certificate received (if required) from manufacturer	<input type="checkbox"/> Yes	<input type="checkbox"/> Yes	
72	Water spray system is operational (5.3.1, 19.4.3)	<input type="checkbox"/> Yes	<input type="checkbox"/> Yes	
73	Appropriate personal protective equipment is identified and available (4.8.1)	<input type="checkbox"/> Yes	<input type="checkbox"/> Yes	
74	Remote control valves are operational	<input type="checkbox"/> Yes	<input type="checkbox"/> Yes	
75	Cargo pumps and compressors are operational	<input type="checkbox"/> Yes	<input type="checkbox"/> Yes	
76	Maximum working pressures are agreed between tanker and terminal (21.4, 21.5, 21.6)	<input type="checkbox"/> Yes	<input type="checkbox"/> Yes	
77	Reliquefaction or boil-off control equipment is operational	<input type="checkbox"/> Yes	<input type="checkbox"/> Yes	
78	Gas detection equipment is appropriately set for the cargo (2.4)	<input type="checkbox"/> Yes	<input type="checkbox"/> Yes	
79	Cargo system gauge operation and alarm set points are confirmed (12.1.6.6.1)	<input type="checkbox"/> Yes	<input type="checkbox"/> Yes	
80	Emergency shutdown systems are tested and operational (18.5)	<input type="checkbox"/> Yes	<input type="checkbox"/> Yes	
81	Cargo handling rate and relationship with valve closure times and automatic shutdown systems is agreed (16.8, 21.4, 21.5, 21.6)	<input type="checkbox"/> Yes	<input type="checkbox"/> Yes	
82	Maximum/minimum temperatures/pressures of the cargo to be transferred are agreed (21.4, 21.5, 21.6)	<input type="checkbox"/> Yes	<input type="checkbox"/> Yes	
83	Cargo tank relief valve settings are confirmed (12.11, 21.2, 21.4)	<input type="checkbox"/> Yes	<input type="checkbox"/> Yes	

Part 6. Tanker and terminal: agreements pre-transfer				
Part 5 item	Agreement	Details	Tanker initials	Terminal initials
32	Tanker manoeuvring readiness	Notice period (maximum) for full readiness to manoeuvre:  Period of disablement (if permitted):		
33	Security protocols	Security level:  Local requirements:		
33	Effective tanker/terminal communications	Primary system:  Backup system:		
35	Operational supervision and watchkeeping	Tanker:  Terminal:		
37 38	Dedicated smoking areas and naked lights restrictions	Tanker:  Terminal:		
45	Maximum wind, current and sea/swell criteria or other environmental factors	Stop cargo transfer:  Disconnect:  Unberth:		
45 46	Limits for cargo, bunkers and ballast handling	Maximum transfer rates:  Topping-off rates:  Maximum manifold pressure:  Cargo temperature:  Other limitations:		

Part 6. Tanker and terminal: agreements pre-transfer (cont.)				
Part 5 item	Agreement	Details	Tanker initials	Terminal initials
45 46	Pressure surge control	Minimum number of cargo tanks open:  Tank switching protocols:  Minimum number of cargo tanks open:  Tank switching protocols:  Full load rate:  Topping-off rate:  Closing time of automatic valves:		
46	Cargo transfer management procedures	Action notice periods:  Transfer stop protocols:		
50	Routine for regular checks on cargo transferred are agreed	Routine transferred quantity checks:		
51	Emergency signals	Tanker:  Terminal:		
55	Tank venting system	Procedure:		
55	Closed operations	Requirements:		
56	Vapour return line	Operational parameters:  Maximum flow rate:		
60	Nitrogen supply from terminal	Procedures to receive:  Maximum pressure:  Flow rate:		

Part 6. Tanker and terminal: agreements pre-transfer (cont.)				
Part 5 item ref	Agreement	Details	Tanker initials	Terminal initials
83	For gas tanker only: cargo tank relief valve settings	Tank 1: Tank 2: Tank 3: Tank 4: Tank 5: Tank 6: Tank 7: Tank 8: Tank 9: Tank 10:		
XX	Exceptions and additions	Special issues that both parties should be aware of:		

Date and time: \_\_\_\_\_

Port and berth: \_\_\_\_\_

Tanker: \_\_\_\_\_

Terminal: \_\_\_\_\_

Product to be transferred: \_\_\_\_\_

Part 7A. General tanker: checks pre-transfer			
Item	Check	Status	Remarks
84	Portable drip trays are correctly positioned and empty (23.7.5)	<input type="checkbox"/> Yes	
85	Individual cargo tank inert gas supply valves are secured for cargo plan (12.1.13.4)	<input type="checkbox"/> Yes	
86	Inert gas system delivering inert gas with oxygen content not more than 5% (11.1.3)	<input type="checkbox"/> Yes	
87	Cargo tank high level alarms are operational (12.1.6.6.1)	<input type="checkbox"/> Yes	
88	All cargo, ballast and bunker tanks openings are secured (23.3)	<input type="checkbox"/> Yes	

Part 7B. Tanker: checks pre-transfer if crude oil washing is planned			
Item	Check	Status	Remarks
89	The completed pre-arrival crude oil washing checklist, as contained in the approved crude oil washing manual, is copied to terminal (12.5.2, 21.2.3)	<input type="checkbox"/> Yes	
90	Crude oil washing checklists for use before, during and after crude oil washing are in place ready to complete, as contained in the approved crude oil washing manual (12.5.2, 21.6)	<input type="checkbox"/> Yes	

## ISGOTT Checks after pre-transfer conference Ship/Shore Safety Checklist

**For tankers that will perform tank cleaning alongside and/or gas freeing alongside**

Part 7C. Tanker: checks prior to tank cleaning and/or gas freeing			
Item	Check	Status	Remarks
91	Permission for tank cleaning operations is confirmed (21.2.3, 21.4, 25.4.3)	<input type="checkbox"/> Yes	
92	Permission for gas freeing operations is confirmed (12.4.3)	<input type="checkbox"/> Yes	
93	Tank cleaning procedures are agreed (12.3.2, 21.4, 21.6)	<input type="checkbox"/> Yes	
94	If cargo tank entry is required, procedures for entry have been agreed with the terminal (10.5)	<input type="checkbox"/> Yes	
95	Slop reception facilities and requirements are confirmed (12.1, 21.2, 21.4)	<input type="checkbox"/> Yes	



**Declaration**

We the undersigned have checked the items in the applicable parts 1 to 7 as marked and signed below:

	Tanker	Terminal
Part 1A. Tanker: checks pre-arrival	<input type="checkbox"/>	<input type="checkbox"/>
Part 1B. Tanker: checks pre-arrival if using an inert gas system	<input type="checkbox"/>	<input type="checkbox"/>
Part 2. Terminal: checks pre-arrival	<input type="checkbox"/>	<input type="checkbox"/>
Part 3. Tanker: checks after mooring	<input type="checkbox"/>	<input type="checkbox"/>
Part 4. Terminal: checks after mooring	<input type="checkbox"/>	<input type="checkbox"/>
Part 5A. Tanker and terminal: pre-transfer conference	<input type="checkbox"/>	<input type="checkbox"/>
Part 5B. Tanker and terminal: bulk liquid chemicals. Checks pre-transfer	<input type="checkbox"/>	<input type="checkbox"/>
Part 5C. Tanker and terminal: liquefied gas. Checks pre-transfer	<input type="checkbox"/>	<input type="checkbox"/>
Part 6. Tanker and terminal: agreements pre-transfer	<input type="checkbox"/>	<input type="checkbox"/>
Part 7A. General tanker: checks pre-transfer	<input type="checkbox"/>	<input type="checkbox"/>
Part 7B. Tanker: checks pre-transfer if crude oil washing is planned	<input type="checkbox"/>	<input type="checkbox"/>
Part 7C. Tanker: checks prior to tank cleaning and/or gas freeing	<input type="checkbox"/>	<input type="checkbox"/>

In accordance with the guidance in chapter 25 of *ISGOTT*, we have satisfied ourselves that the entries we have made are correct to the best of our knowledge and that the tanker and terminal are in agreement to undertake the transfer operation.

We have also agreed to carry out the repetitive checks noted in parts 9 and 10 of the *ISGOTT* SSSCL, which should occur at intervals of not more than \_\_\_\_ hours for the tanker and not more than \_\_\_\_ hours for the terminal.

If, to our knowledge, the status of any item changes, we will immediately inform the other party.

Tanker	Terminal
Name	Name
Rank	Position
Signature	Signature
Date	Date
Time	Time

## ISGOTT Checks during transfer Ship/Shore Safety Checklist

### Repetitive checks

Part 8. Tanker: repetitive checks during and after transfer								
Item ref	Check	Time	Time	Time	Time	Time	Time	Remarks
Interval time:..... hrs								
8	Inert gas system pressure and oxygen recording operational	<input type="checkbox"/> Yes	<input type="checkbox"/> Yes	<input type="checkbox"/> Yes	<input type="checkbox"/> Yes	<input type="checkbox"/> Yes	<input type="checkbox"/> Yes	
9	Inert gas system and all associated equipment are operational	<input type="checkbox"/> Yes	<input type="checkbox"/> Yes	<input type="checkbox"/> Yes	<input type="checkbox"/> Yes	<input type="checkbox"/> Yes	<input type="checkbox"/> Yes	
11	Cargo tank atmospheres are at positive pressure	<input type="checkbox"/> Yes	<input type="checkbox"/> Yes	<input type="checkbox"/> Yes	<input type="checkbox"/> Yes	<input type="checkbox"/> Yes	<input type="checkbox"/> Yes	
18	Mooring arrangement is effective	<input type="checkbox"/> Yes	<input type="checkbox"/> Yes	<input type="checkbox"/> Yes	<input type="checkbox"/> Yes	<input type="checkbox"/> Yes	<input type="checkbox"/> Yes	
19	Access to and from the tanker is safe	<input type="checkbox"/> Yes	<input type="checkbox"/> Yes	<input type="checkbox"/> Yes	<input type="checkbox"/> Yes	<input type="checkbox"/> Yes	<input type="checkbox"/> Yes	
20	Scuppers and savealls are plugged	<input type="checkbox"/> Yes	<input type="checkbox"/> Yes	<input type="checkbox"/> Yes	<input type="checkbox"/> Yes	<input type="checkbox"/> Yes	<input type="checkbox"/> Yes	
23	External openings in superstructures are controlled	<input type="checkbox"/> Yes	<input type="checkbox"/> Yes	<input type="checkbox"/> Yes	<input type="checkbox"/> Yes	<input type="checkbox"/> Yes	<input type="checkbox"/> Yes	
24	Pumproom ventilation is effective	<input type="checkbox"/> Yes	<input type="checkbox"/> Yes	<input type="checkbox"/> Yes	<input type="checkbox"/> Yes	<input type="checkbox"/> Yes	<input type="checkbox"/> Yes	
28	Tanker is ready to move at agreed notice period	<input type="checkbox"/> Yes	<input type="checkbox"/> Yes	<input type="checkbox"/> Yes	<input type="checkbox"/> Yes	<input type="checkbox"/> Yes	<input type="checkbox"/> Yes	
29	Fendering is effective	<input type="checkbox"/> Yes	<input type="checkbox"/> Yes	<input type="checkbox"/> Yes	<input type="checkbox"/> Yes	<input type="checkbox"/> Yes	<input type="checkbox"/> Yes	
33	Communications are effective	<input type="checkbox"/> Yes	<input type="checkbox"/> Yes	<input type="checkbox"/> Yes	<input type="checkbox"/> Yes	<input type="checkbox"/> Yes	<input type="checkbox"/> Yes	
35	Supervision and watchkeeping is adequate	<input type="checkbox"/> Yes	<input type="checkbox"/> Yes	<input type="checkbox"/> Yes	<input type="checkbox"/> Yes	<input type="checkbox"/> Yes	<input type="checkbox"/> Yes	
36	Sufficient personnel are available to deal with an emergency	<input type="checkbox"/> Yes	<input type="checkbox"/> Yes	<input type="checkbox"/> Yes	<input type="checkbox"/> Yes	<input type="checkbox"/> Yes	<input type="checkbox"/> Yes	
37	Smoking restrictions and designated smoking areas are complied with	<input type="checkbox"/> Yes	<input type="checkbox"/> Yes	<input type="checkbox"/> Yes	<input type="checkbox"/> Yes	<input type="checkbox"/> Yes	<input type="checkbox"/> Yes	
38	Naked light restrictions are complied with	<input type="checkbox"/> Yes	<input type="checkbox"/> Yes	<input type="checkbox"/> Yes	<input type="checkbox"/> Yes	<input type="checkbox"/> Yes	<input type="checkbox"/> Yes	

Part 8. Tanker: repetitive checks during and after transfer (cont.)								
39	Control of electrical devices and equipment in hazardous zones is complied with	<input type="checkbox"/> Yes	<input type="checkbox"/> Yes	<input type="checkbox"/> Yes	<input type="checkbox"/> Yes	<input type="checkbox"/> Yes	<input type="checkbox"/> Yes	
40 41 42 51	Emergency response preparedness is satisfactory	<input type="checkbox"/> Yes	<input type="checkbox"/> Yes	<input type="checkbox"/> Yes	<input type="checkbox"/> Yes	<input type="checkbox"/> Yes	<input type="checkbox"/> Yes	
54	Electrical insulation of the tanker/terminal interface is effective	<input type="checkbox"/> Yes	<input type="checkbox"/> Yes	<input type="checkbox"/> Yes	<input type="checkbox"/> Yes	<input type="checkbox"/> Yes	<input type="checkbox"/> Yes	
55	Tank venting system and closed operation procedures are as agreed	<input type="checkbox"/> Yes	<input type="checkbox"/> Yes	<input type="checkbox"/> Yes	<input type="checkbox"/> Yes	<input type="checkbox"/> Yes	<input type="checkbox"/> Yes	
85	Individual cargo tank inert gas valves settings are as agreed	<input type="checkbox"/> Yes	<input type="checkbox"/> Yes	<input type="checkbox"/> Yes	<input type="checkbox"/> Yes	<input type="checkbox"/> Yes	<input type="checkbox"/> Yes	
86	Inert gas delivery maintained at not more than 5% oxygen	<input type="checkbox"/> Yes	<input type="checkbox"/> Yes	<input type="checkbox"/> Yes	<input type="checkbox"/> Yes	<input type="checkbox"/> Yes	<input type="checkbox"/> Yes	
87	Cargo tank high level alarms are operational	<input type="checkbox"/> Yes	<input type="checkbox"/> Yes	<input type="checkbox"/> Yes	<input type="checkbox"/> Yes	<input type="checkbox"/> Yes	<input type="checkbox"/> Yes	
<b>Initials</b>								

Part 9. Terminal: repetitive checks during and after transfer								
Item ref	Check	Time	Time	Time	Time	Time	Time	Remarks
Interval time:..... hrs								
18	Mooring arrangement is effective	<input type="checkbox"/> Yes	<input type="checkbox"/> Yes	<input type="checkbox"/> Yes	<input type="checkbox"/> Yes	<input type="checkbox"/> Yes	<input type="checkbox"/> Yes	
19	Access to and from the terminal is safe	<input type="checkbox"/> Yes	<input type="checkbox"/> Yes	<input type="checkbox"/> Yes	<input type="checkbox"/> Yes	<input type="checkbox"/> Yes	<input type="checkbox"/> Yes	
29	Fendering is effective	<input type="checkbox"/> Yes	<input type="checkbox"/> Yes	<input type="checkbox"/> Yes	<input type="checkbox"/> Yes	<input type="checkbox"/> Yes	<input type="checkbox"/> Yes	
32	Spill containment and sumps are secure	<input type="checkbox"/> Yes	<input type="checkbox"/> Yes	<input type="checkbox"/> Yes	<input type="checkbox"/> Yes	<input type="checkbox"/> Yes	<input type="checkbox"/> Yes	
33	Communications are effective	<input type="checkbox"/> Yes	<input type="checkbox"/> Yes	<input type="checkbox"/> Yes	<input type="checkbox"/> Yes	<input type="checkbox"/> Yes	<input type="checkbox"/> Yes	
35	Supervision and watchkeeping is adequate	<input type="checkbox"/> Yes	<input type="checkbox"/> Yes	<input type="checkbox"/> Yes	<input type="checkbox"/> Yes	<input type="checkbox"/> Yes	<input type="checkbox"/> Yes	
36	Sufficient personnel are available to deal with an emergency	<input type="checkbox"/> Yes	<input type="checkbox"/> Yes	<input type="checkbox"/> Yes	<input type="checkbox"/> Yes	<input type="checkbox"/> Yes	<input type="checkbox"/> Yes	
37	Smoking restrictions and designated smoking areas are complied with	<input type="checkbox"/> Yes	<input type="checkbox"/> Yes	<input type="checkbox"/> Yes	<input type="checkbox"/> Yes	<input type="checkbox"/> Yes	<input type="checkbox"/> Yes	
38	Naked light restrictions are complied with	<input type="checkbox"/> Yes	<input type="checkbox"/> Yes	<input type="checkbox"/> Yes	<input type="checkbox"/> Yes	<input type="checkbox"/> Yes	<input type="checkbox"/> Yes	
39	Control of electrical devices and equipment in hazardous zones is complied with	<input type="checkbox"/> Yes	<input type="checkbox"/> Yes	<input type="checkbox"/> Yes	<input type="checkbox"/> Yes	<input type="checkbox"/> Yes	<input type="checkbox"/> Yes	
40 41 47 51	Emergency response preparedness is satisfactory	<input type="checkbox"/> Yes	<input type="checkbox"/> Yes	<input type="checkbox"/> Yes	<input type="checkbox"/> Yes	<input type="checkbox"/> Yes	<input type="checkbox"/> Yes	
54	Electrical insulation of the tanker/terminal interface is effective	<input type="checkbox"/> Yes	<input type="checkbox"/> Yes	<input type="checkbox"/> Yes	<input type="checkbox"/> Yes	<input type="checkbox"/> Yes	<input type="checkbox"/> Yes	
55	Tank venting system and closed operation procedures are as agreed	<input type="checkbox"/> Yes	<input type="checkbox"/> Yes	<input type="checkbox"/> Yes	<input type="checkbox"/> Yes	<input type="checkbox"/> Yes	<input type="checkbox"/> Yes	
Initials								

### 3. Fender Certificates

**Fender Pressure Test Certificate**

**Record of Examination**

Location	Greece, Alexandroupoli
Date the record is made	04/Apr/2024
Owner of fender	Gaslog Ltd.
Manufacturer of fender	Trelleborg
Description of fender (with size)	9000 X 4500
Pressure	50KPa
ISO 17357	Yes
Reinforcement	Tyre Cord

**Fender End Plate**

ISO 7357	Yes
Serial No	TBI4590-5-1906-041
Date of Manufacture	23/03/2021
Initial Internal Pressure	50KPa

**Lift Safety Relief Valve**

Internal or external mount Type	Internal- A48X – 10P DN125
Size	240 X 135
Fluid	Air
Temperature	20 Degrees
Set Pressure	1.8 Bar
MGF No	B19040008

**Pressure Test**

Test Gauge last calibrated:	20/05/2023
Blow off pressure:	1.8 Bar

**Notes**

Fender and Valve in Good Condition

**Test Performed by:** Ian Corse

**Next Due Date:** 03/04/2026

**DECLARATION**

I hereby declare that the equipment described in this record was tested, tested and examined or tested and thoroughly examined in accordance with the appropriate provisions and is found free from any defect likely to affect safety on and that the above particulars are correct.

Name of any person making above record.

Ian Corse on behalf of STS Marine Solutions

Signature

*I Corse*



### Fender Pressure Test Certificate

**Record of Examination**

Location	Greece, Alexandroupoli
Date the record is made	05/Apr/2024
Owner of fender	Gaslog Ltd.
Manufacturer of fender	Trelleborg
Description of fender (with size)	9000 X 4500
Pressure	50KPa
ISO 17357	Yes
Reinforcement	Tyre Cord

**Fender End Plate**

ISO 7357	Yes
Serial No	TBI4590-5-2006-049
Date of Manufacture	23/03/2021
Initial Internal Pressure	50KPa

**Lift Safety Relief Valve**

Internal or external mount Type	Internal- A48X – 10P DN125
Size	240 X 135
Fluid	Air
Temperature	20 Degrees
Set Pressure	1.8 Bar
MGF No	B20080044

**Pressure Test**

Test Gauge last calibrated:	20/05/2023
Blow off pressure:	1.8 Bar

**Notes**

Fender and Valve in Good Condition

Test Performed by: Ian Corse

Next Due Date: 04/04/2026

DECLARATION	I hereby declare that the equipment described in this record was tested, tested and examined or tested and thoroughly examined in accordance with the appropriate provisions and is found free from any defect likely to affect safety on and that the above particulars are correct.
Name of any person making above record.	Ian Corse on behalf of STS Marine Solutions
Signature	<i>I Corse</i>

SPT MARINE TRANSFER SERVICES LTD  
Suite 504  
22 Victoria Street  
Hamilton MH12  
Bermuda  
Tel: +44 191 5681820

### Fender Pressure Test Certificate

#### Record of Examination

Location	Greece, Alexandroupoli
Date the record is made	04/Apr/2024
Owner of fender	Gaslog Ltd
Manufacturer of fender	Trelleborg
Description of fender (with size)	9000 X 4500
Pressure	50KPa
ISO 17357	Yes
Reinforcement	Tyre Cord

#### Fender End Plate

ISO 7357	Yes
Serial No	TBI4590-5-2103-019
Date of Manufacture	23/03/2021
Initial Internal Pressure	50KPa

#### Lift Safety Relief Valve

Internal or external mount Type	Internal- A48X – 10P DN125
Size	240 X 135
Fluid	Air
Temperature	20 Degrees
Set Pressure	1.8 Bar
MGF No	B21010005

#### Pressure Test

Test Gauge last calibrated:	20/05/2023
Blow off pressure:	1.8 Bar

#### Notes

Fender and Valve in Good Condition

Test Performed by: Ian Corse

Next Due Date: 03/04/2026

#### DECLARATION

I hereby declare that the equipment described in this record was tested, tested and examined or tested and thoroughly examined in accordance with the appropriate provisions and is found free from any defect likely to affect safety on and that the above particulars are correct.

Name of any person making above record.

Ian Corse on behalf of STS Marine Solutions

Signature

*I Corse*





### Fender Pressure Test Certificate

#### Record of Examination

Location	Greece, Alexandroupoli
Date the record is made	05/Apr/2024
Owner of fender	Gaslog Ltd
Manufacturer of fender	Trelleborg
Description of fender (with size)	9000 X 4500
Pressure	50KPa
ISO 17357	Yes
Reinforcement	Tyre Cord

#### Fender End Plate

ISO 7357	Yes
Serial No	TBI4590-5-2105-032
Date of Manufacture	23/03/2021
Initial Internal Pressure	50KPa

#### Lift Safety Relief Valve

Internal or external mount Type	Internal- A48X – 10P DN125
Size	240 X 135
Fluid	Air
Temperature	20 Degrees
Set Pressure	1.8 Bar
MGF No	B21030009

#### Pressure Test

Test Gauge last calibrated:	20/05/2023
Blow off pressure:	1.8 Bar

#### Notes

Fender and Valve in Good Condition

Test Performed by: Ian Corse

Next Due Date: 04/04/2026

DECLARATION	I hereby declare that the equipment described in this record was tested, tested and examined or tested and thoroughly examined in accordance with the appropriate provisions and is found free from any defect likely to affect safety on and that the above particulars are correct.
Name of any person making above record.	Ian Corse on behalf of STS Marine Solutions
Signature	<i>I Corse</i>

SPT MARINE TRANSFER SERVICES LTD  
Suite 504  
22 Victoria Street  
Hamilton MH12  
Bermuda  
Tel: +44 191 5681820

## 4. Hose Certificates

## Certificate of inspection & Test according to EN 10204 3.1

<b>Customer</b>	Gasloch LNG Services Ltd.	<b>Our Reference</b>	GSO241225
<b>Your Reference</b>	Re-test FSRU Alexandroupolis	<b>Manometer</b>	
		<b>Date</b>	19-06-24
<b>Hose Type</b>	Multi-L.N.G. White 10" SS/PM 10 bar		
<b>Item No.</b>	G281039375250_F		
<b>Length</b>	18 Mtr		
<b>Diameter</b>	10"		
<b>Connection 1</b>	PHKC-SSS-FLOAT.ASA150-10"250MM LNG 3.2		
<b>Connection 2</b>	PHKC-SSS-FLOAT.ASA150-10"250MM LNG 3.2		

Serial No.	From Temp. (Celc)	Till Temp. (Celc)	Work Press. (Bar)	Test Press. (Bar)	Length before test (Mtr)	Length during test (Mtr)	Length after test (Mtr)	Final Length (Mtr)	Electr. Resist. (Ohm)	Weight (P/KG)
247718-06-24	-196,00	50,00	10,00	15,00	18,91	20,14	19,51	18,15	5,10	23,90

**Inspection Date: 13-06-24**

Pressure ratings: 0.7 bar/10 PSI at length before and after test  
1,5 time working pressure at length during test

**Remarks**

Hose Assemblies produced, tested and certified by third party according to EN 13766 /EN1474-II  
Extra engraved in ferrule : MAX FLOWRATE 2250 m3/Hr  
DNV TEST N142JW9W - TP 15 BAR - Dated 08-03-2023.  
Flange Heatno : 117479 - CF060  
Tailpiece Heatno : PCC040787

Re-tested on board of the FSRU Alexandroupolis date: 13-06-24

**Tested By**

**Approved By** Frank Maaskant

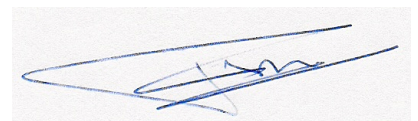

## Certificate of inspection & Test according to EN 10204 3.1

<b>Customer</b>	Gasloch LNG Services Ltd.	<b>Our Reference</b>	GSO241225
<b>Your Reference</b>	Re-test FSRU Alexandroupolis	<b>Manometer</b>	
		<b>Date</b>	18-06-24
<b>Hose Type</b>	Multi-L.N.G. White 10" SS/PM 10 bar		
<b>Item No.</b>	G281039375250_F		
<b>Length</b>	18 Mtr		
<b>Diameter</b>	10"		
<b>Connection 1</b>	PHKC-SSS-FLOAT.ASA150-10"250MM LNG 3.2		
<b>Connection 2</b>	PHKC-SSS-FLOAT.ASA150-10"250MM LNG 3.2		

Serial No.	From Temp. (Celc)	Till Temp. (Celc)	Work Press. (Bar)	Test Press. (Bar)	Length before test (Mtr)	Length during test (Mtr)	Length after test (Mtr)	Final Length (Mtr)	Electr. Resist. (Ohm)	Weight (P/KG)
247719-06-24	-196,00	50,00	10,00	15,00	18,98	20,21	19,65	18,13	4,41	23,90

**Inspection Date: 12-06-24**

Pressure ratings: 0.7 bar/10 PSI at length before and after test  
 1,5 time working pressure at length during test

**Remarks**

Hose Assemblies produced, tested and certified by third party according to EN 13766 /EN1474-II  
 Extra engraved in ferrule : MAX FLOWRATE 2250 m3/Hr  
 DNV TEST N142JW9W - TP 15 BAR - Dated 08-03-2023.  
 Flange Heatno : 117479 - CF060  
 Tailpiece Heatno : PCC040787

Re-tested on board of the FSRU Alexandroupolis date: 12-06-24

**Tested By** Edwin Spruijt

**Approved By** Frank Maaskant

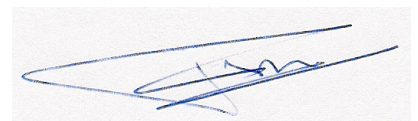

## Certificate of inspection & Test according to EN 10204 3.1

<b>Customer</b>	Gasloch LNG Services Ltd.	<b>Our Reference</b>	GSO241225
<b>Your Reference</b>	Re-test FSRU Alexandroupolis	<b>Manometer</b>	
		<b>Date</b>	18-06-24
<b>Hose Type</b>	Multi-L.N.G. White 10" SS/PM 10 bar		
<b>Item No.</b>	G281039375250_F		
<b>Length</b>	18 Mtr		
<b>Diameter</b>	10"		
<b>Connection 1</b>	PHKC-SSS-FLOAT.ASA150-10"250MM LNG 3.2		
<b>Connection 2</b>	PHKC-SSS-FLOAT.ASA150-10"250MM LNG 3.2		

Serial No.	From Temp. (Celc)	Till Temp. (Celc)	Work Press. (Bar)	Test Press. (Bar)	Length before test (Mtr)	Length during test (Mtr)	Length after test (Mtr)	Final Length (Mtr)	Electr. Resist. (Ohm)	Weight (P/KG)
247720-06-24	-196,00	50,00	10,00	15,00	18,51	20,19	19,79	18,12	4,40	23,90

**Inspection Date: 11-06-24**

Pressure ratings: 0.7 bar/10 PSI at length before and after test  
1,5 time working pressure at length during test

**Remarks**

Hose Assemblies produced, tested and certified by third party according to EN 13766 /EN1474-II  
Extra engraved in ferrule : MAX FLOWRATE 2250 m3/Hr  
DNV TEST N142JW9W - TP 15 BAR - Dated 08-03-2023.  
Flange Heatno : 117479 - CF060  
Tailpiece Heatno : PCC040787

Re-tested on board of the FSRU Alexandroupolis date: 11-06-24

**Tested By** Edwin Spruijt

**Approved By** Frank Maaskant

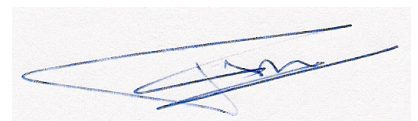

## Certificate of inspection & Test according to EN 10204 3.1

<b>Customer</b>	Gasloch LNG Services Ltd.	<b>Our Reference</b>	GSO241225
<b>Your Reference</b>	Re-test FSRU Alexandroupolis	<b>Manometer</b>	
		<b>Date</b>	18-06-24
<b>Hose Type</b>	Multi-L.N.G. White 10" SS/PM 10 bar		
<b>Item No.</b>	G281039375250_F		
<b>Length</b>	18 Mtr		
<b>Diameter</b>	10"		
<b>Connection 1</b>	PHKC-SSS-FLOAT.ASA150-10"250MM LNG 3.2		
<b>Connection 2</b>	PHKC-SSS-FLOAT.ASA150-10"250MM LNG 3.2		

Serial No.	From Temp. (Celc)	Till Temp. (Celc)	Work Press. (Bar)	Test Press. (Bar)	Length before test (Mtr)	Length during test (Mtr)	Length after test (Mtr)	Final Length (Mtr)	Electr. Resist. (Ohm)	Weight (P/KG)
247721-06-24	-196,00	50,00	10,00	15,00	18,91	20,25	19,59	18,20	4,41	23,90

**Inspection Date: 11-06-24**

Pressure ratings: 0.7 bar/10 PSI at length before and after test  
1,5 time working pressure at length during test

**Remarks**

Hose Assemblies produced, tested and certified by third party according to EN 13766 /EN1474-II  
Extra engraved in ferrule : MAX FLOWRATE 2250 m3/Hr  
DNV TEST N142JW9W - TP 15 BAR - Dated 08-03-2023.  
Flange Heatno : 117479 - CF060  
Tailpiece Heatno : PCC040787

Re-tested on board of the FSRU Alexandroupolis date: 11-06-24

**Tested By** Edwin Spruijt

**Approved By** Frank Maaskant

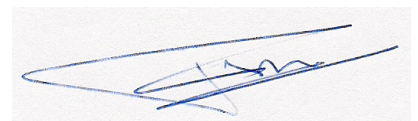

## Certificate of inspection & Test according to EN 10204 3.1

<b>Customer</b>	Gasloch LNG Services Ltd.	<b>Our Reference</b>	GSO241225
<b>Your Reference</b>	Re-test FSRU Alexandroupolis	<b>Manometer</b>	
		<b>Date</b>	18-06-24
<b>Hose Type</b>	Multi-L.N.G. White 10" SS/PM 10 bar		
<b>Item No.</b>	G281039375250_F		
<b>Length</b>	18 Mtr		
<b>Diameter</b>	10"		
<b>Connection 1</b>	PHKC-SSS-FLOAT.ASA150-10"250MM LNG 3.2		
<b>Connection 2</b>	PHKC-SSS-FLOAT.ASA150-10"250MM LNG 3.2		

Serial No.	From Temp. (Celc)	Till Temp. (Celc)	Work Press. (Bar)	Test Press. (Bar)	Length before test (Mtr)	Length during test (Mtr)	Length after test (Mtr)	Final Length (Mtr)	Electr. Resist. (Ohm)	Weight (P/KG)
247723-06-24	-196,00	50,00	10,00	15,00	18,95	20,35	19,60	18,19	4,43	23,90

**Inspection Date: 11-06-24**

Pressure ratings: 0.7 bar/10 PSI at length before and after test  
1,5 time working pressure at length during test

**Remarks**

Hose Assemblies produced, tested and certified by third party according to EN 13766 /EN1474-II  
Extra engraved in ferrule : MAX FLOWRATE 2250 m3/Hr  
DNV TEST N142JW9W - TP 15 BAR - Dated 08-03-2023.  
Flange Heatno : 117479 - CF060  
Tailpiece Heatno : PCC040787

Re-tested on board of the FSRU Alexandroupolis date: 11-06-24

**Tested By** Edwin Spruijt

**Approved By** Frank Maaskant

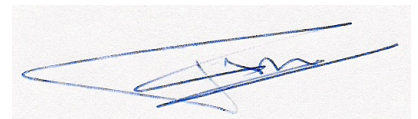

## Certificate of inspection & Test according to EN 10204 3.1

<b>Customer</b>	Gasloch LNG Services Ltd.	<b>Our Reference</b>	GSO241225
<b>Your Reference</b>	Re-test FSRU Alexandroupolis	<b>Manometer</b>	
		<b>Date</b>	19-06-24
<b>Hose Type</b>	Multi-L.N.G. White 10" SS/PM 10 bar		
<b>Item No.</b>	G281039375250_F		
<b>Length</b>	18 Mtr		
<b>Diameter</b>	10"		
<b>Connection 1</b>	PHKC-SSS-FLOAT.ASA150-10"250MM LNG 3.2		
<b>Connection 2</b>	PHKC-SSS-FLOAT.ASA150-10"250MM LNG 3.2		

Serial No.	From Temp. (Celc)	Till Temp. (Celc)	Work Press. (Bar)	Test Press. (Bar)	Length before test (Mtr)	Length during test (Mtr)	Length after test (Mtr)	Final Length (Mtr)	Electr. Resist. (Ohm)	Weight (P/KG)
247724-06-24	-196,00	50,00	10,00	15,00	18,85	20,03	19,48	17,97	6,50	23,90

**Inspection Date: 13-06-24**

Pressure ratings: 0.7 bar/10 PSI at length before and after test  
1,5 time working pressure at length during test

**Remarks**

Hose Assemblies produced, tested and certified by third party according to EN 13766 /EN1474-II  
Extra engraved in ferrule : MAX FLOWRATE 2250 m3/Hr  
DNV TEST N142JW9W - TP 15 BAR - Dated 08-03-2023.  
Flange Heatno : 117479 - CF060  
Tailpiece Heatno : PCC040787

Re-tested on board of the FSRU Alexandroupolis date: 13-06-24

**Tested By**

**Approved By** Frank Maaskant

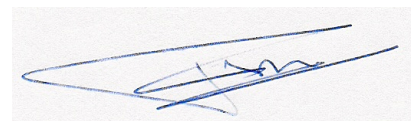



## Certificate of inspection & Test according to EN 10204 3.1

<b>Customer</b>	Gasloch LNG Services Ltd.	<b>Our Reference</b>	GSO241225
<b>Your Reference</b>	Re-test FSRU Alexandroupolis	<b>Manometer</b>	
		<b>Date</b>	19-06-24
<b>Hose Type</b>	Multi-L.N.G. White 10" SS/PM 10 bar		
<b>Item No.</b>	G281039375250_F		
<b>Length</b>	18 Mtr		
<b>Diameter</b>	10"		
<b>Connection 1</b>	PHKC-SSS-FLOAT.ASA150-10"250MM LNG 3.2		
<b>Connection 2</b>	PHKC-SSS-FLOAT.ASA150-10"250MM LNG 3.2		

Serial No.	From Temp. (Celc)	Till Temp. (Celc)	Work Press. (Bar)	Test Press. (Bar)	Length before test (Mtr)	Length during test (Mtr)	Length after test (Mtr)	Final Length (Mtr)	Electr. Resist. (Ohm)	Weight (P/KG)
247722-06-24	-196,00	50,00	10,00	15,00	18,80	20,10	19,45	18,15	5,40	23,90

**Inspection Date: 13-06-24**

Pressure ratings: 0.7 bar/10 PSI at length before and after test  
1,5 time working pressure at length during test

**Remarks**

Hose Assemblies produced, tested and certified by third party according to EN 13766 /EN1474-II  
Extra engraved in ferrule : MAX FLOWRATE 2250 m3/Hr  
DNV TEST N142JW9W - TP 15 BAR - Dated 08-03-2023.  
Flange Heatno : 117479 - CF060  
Tailpiece Heatno : PCC040787

Re-tested on board of the FSRU Alexandroupolis date: 13-06-24

**Tested By**

**Approved By** Frank Maaskant

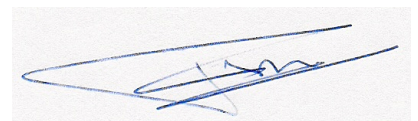

## Certificate of inspection & Test according to EN 10204 3.1

<b>Customer</b>	Gasloch LNG Services Ltd.	<b>Our Reference</b>	GSO241225
<b>Your Reference</b>	Re-test FSRU Alexandroupolis	<b>Manometer</b>	
		<b>Date</b>	17-06-24
<b>Hose Type</b>	Multi-L.N.G. White 10" SS/PM 10 bar		
<b>Item No.</b>	G281039375250_F		
<b>Length</b>	18 Mtr		
<b>Diameter</b>	10"		
<b>Connection 1</b>	PHKC-SSS-FLOAT.ASA150-10"250MM LNG 3.2		
<b>Connection 2</b>	PHKC-SSS-FLOAT.ASA150-10"250MM LNG 3.2		

Serial No.	From Temp. (Celc)	Till Temp. (Celc)	Work Press. (Bar)	Test Press. (Bar)	Length before test (Mtr)	Length during test (Mtr)	Length after test (Mtr)	Final Length (Mtr)	Electr. Resist. (Ohm)	Weight (P/KG)
247717-06-24	-196,00	50,00	10,00	15,00	18,96	20,36	19,65	18,19	4,45	23,90

**Inspection Date: 11-06-24**

Pressure ratings: 0.7 bar/10 PSI at length before and after test  
1,5 time working pressure at length during test

**Remarks**

Hose Assemblies produced, tested and certified by third party according to EN 13766 /EN1474-II  
Extra engraved in ferrule : MAX FLOWRATE 2250 m3/Hr  
DNV TEST N142JW9W - TP 15 BAR - Dated 08-03-2023.  
Flange Heatno : 117479 - CF060  
Tailpiece Heatno : PCC040787

Re-tested on board of the FSRU Alexandroupolis date: 11-06-24

**Tested By** Edwin Spruijt

**Approved By** Frank Maaskant

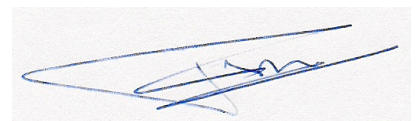

## 5. PROPOSED MOORING PLAN

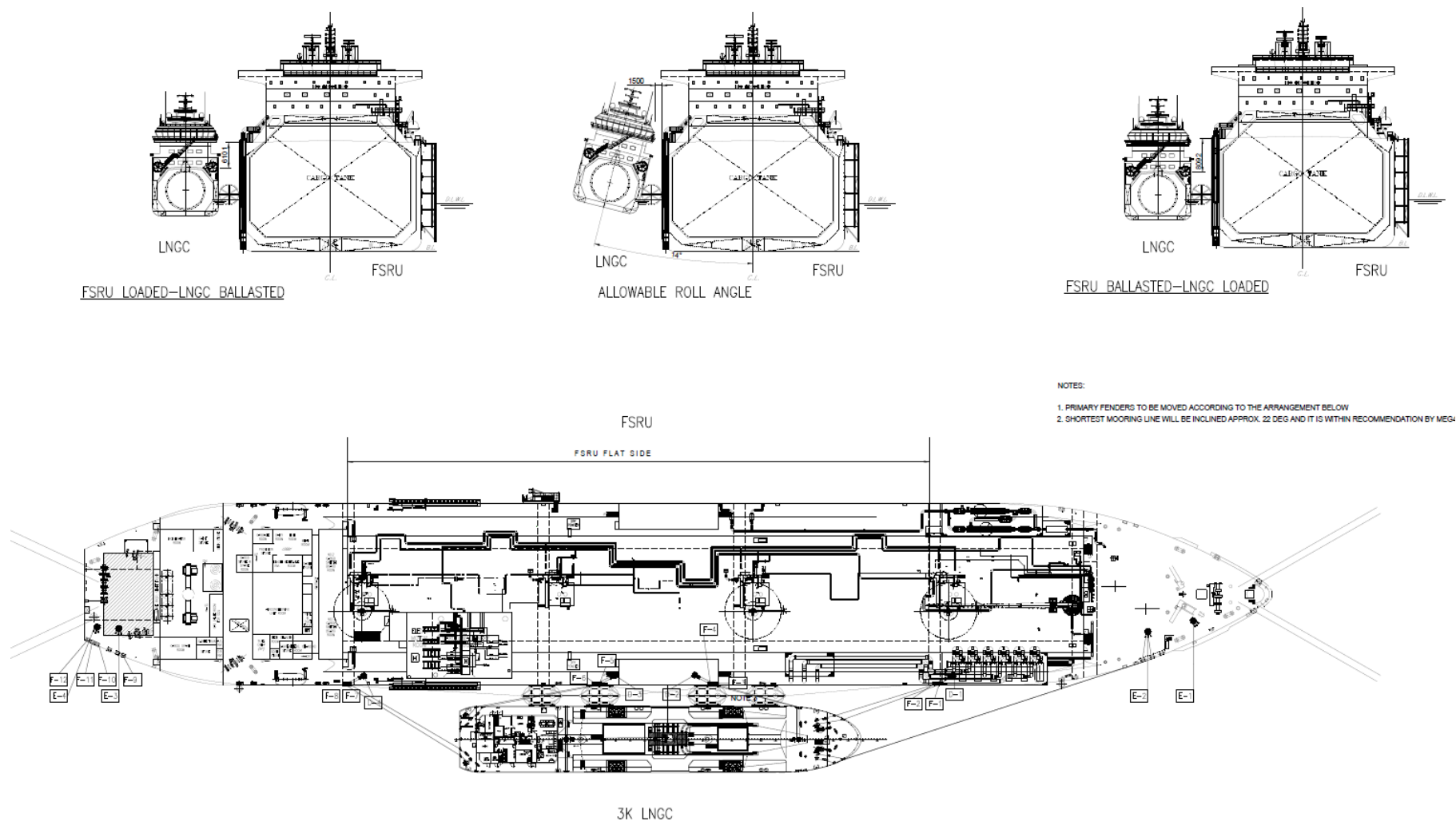
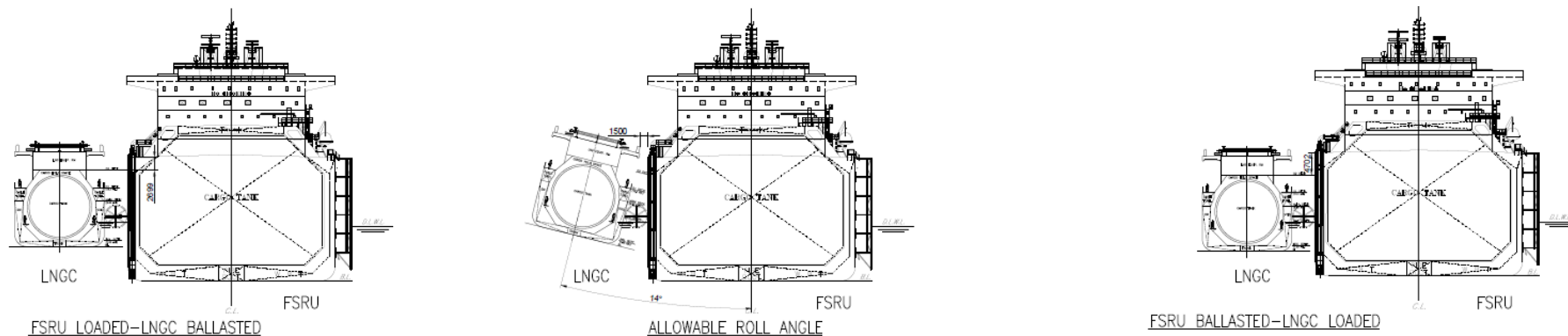

Figure 16 Proposed mooring plan with up to 3000 LNGC



NOTES:  
 1. PRIMARY FENDERS TO BE MOVED ACCORDING TO THE ARRANGEMENT BELOW  
 2. SHORTEST MOORING LINE WILL BE INCLINED APPROX. 18 DEG AND IT IS WITHIN RECOMMENDATION BY MEG4

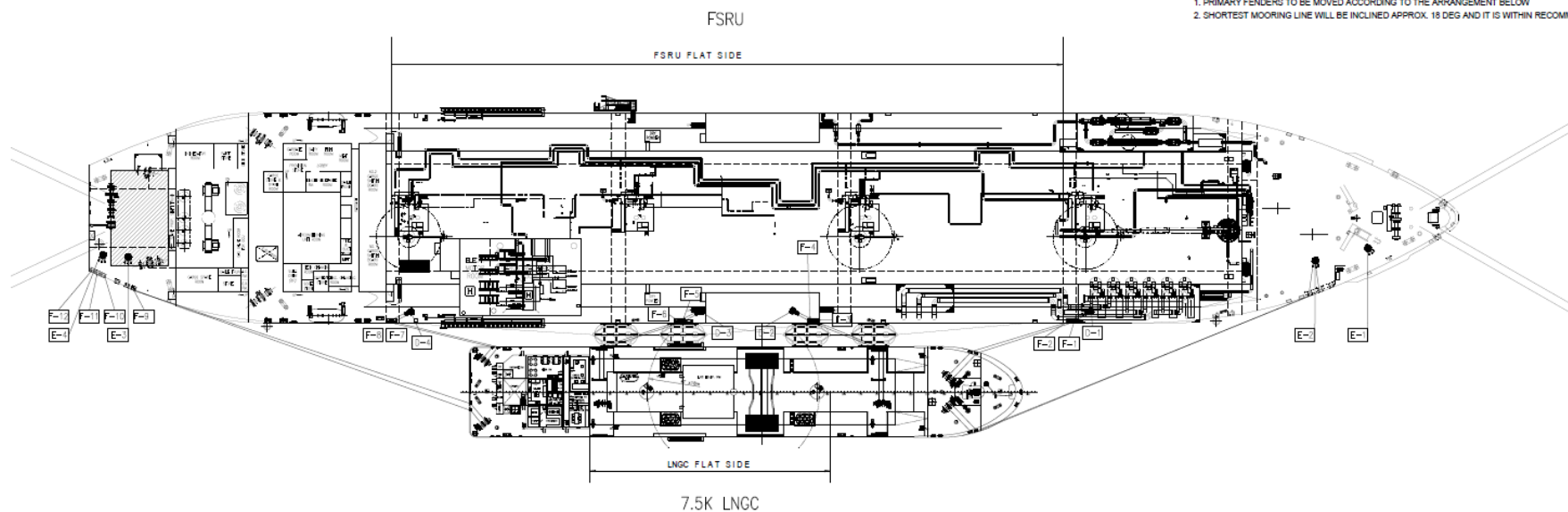

Figure 17 Proposed mooring plan with up to 7500 LNGC

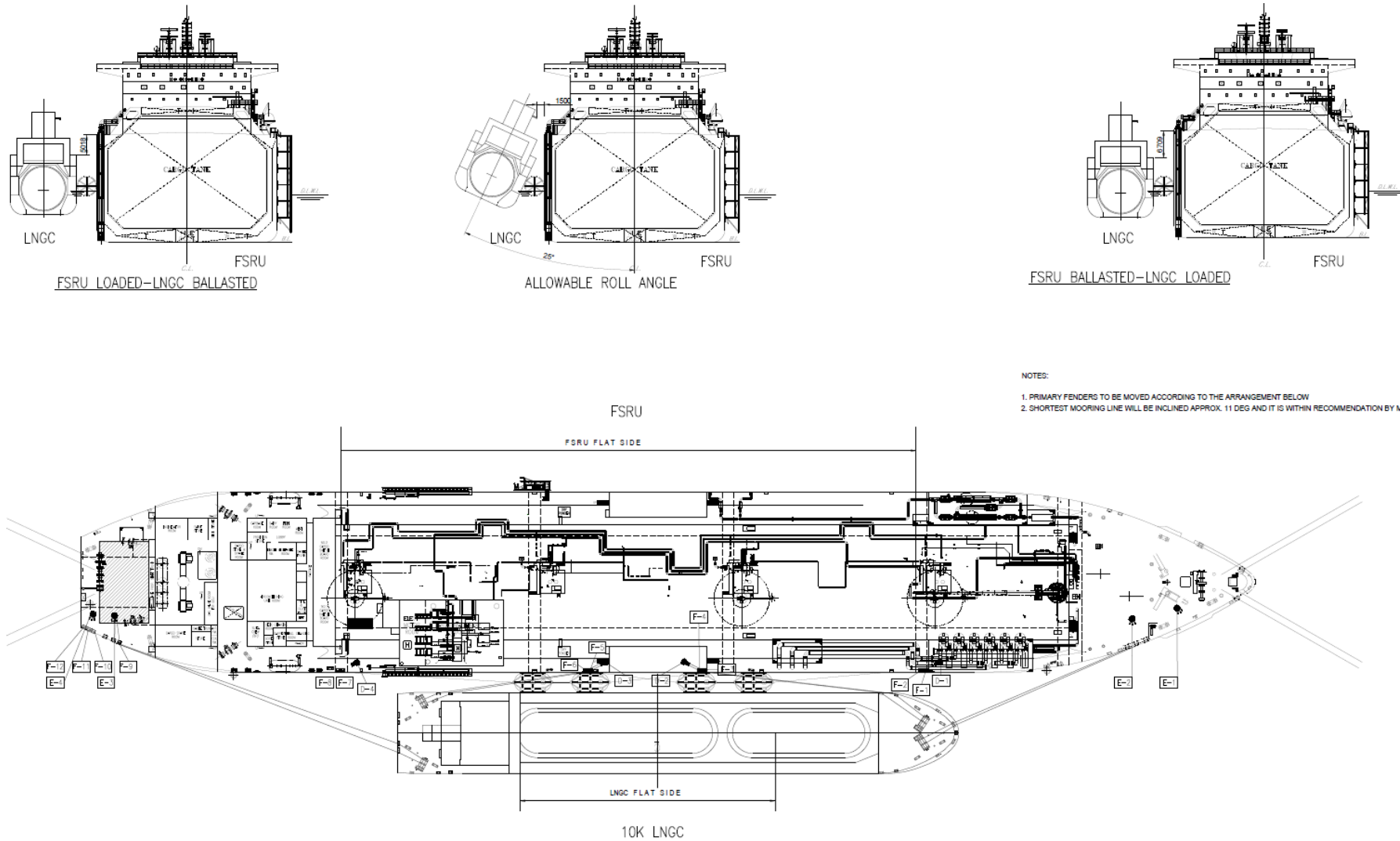
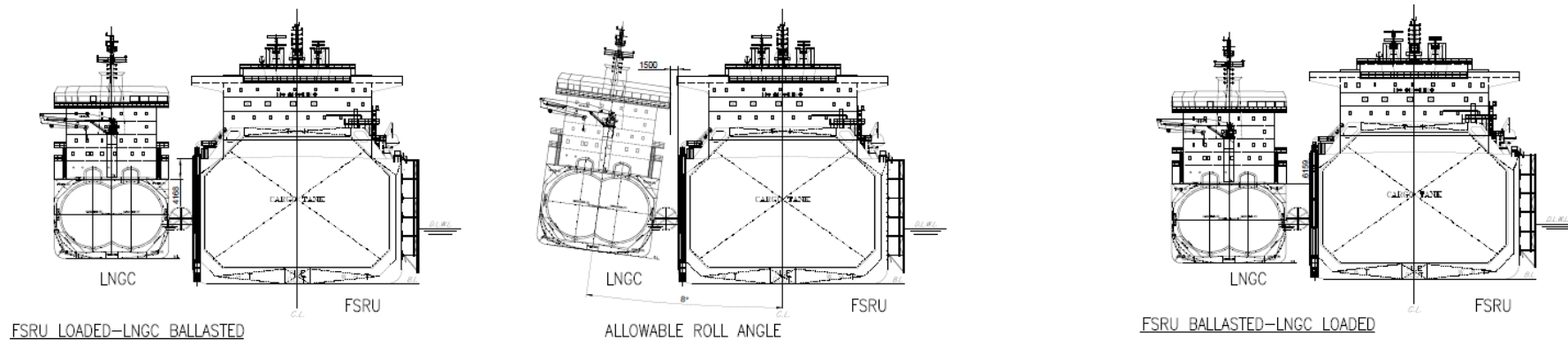

Figure 18 Proposed mooring plan with up to 10000 LNGC



- NOTES:
1. PRIMARY FENDERS TO BE MOVED ACCORDING TO THE ARRANGEMENT BELOW
  2. SHORTEST MOORING LINE WILL BE INCLINED APPROX. 19 DEG AND IT IS WITHIN RECOMMENDATION BY MEG4

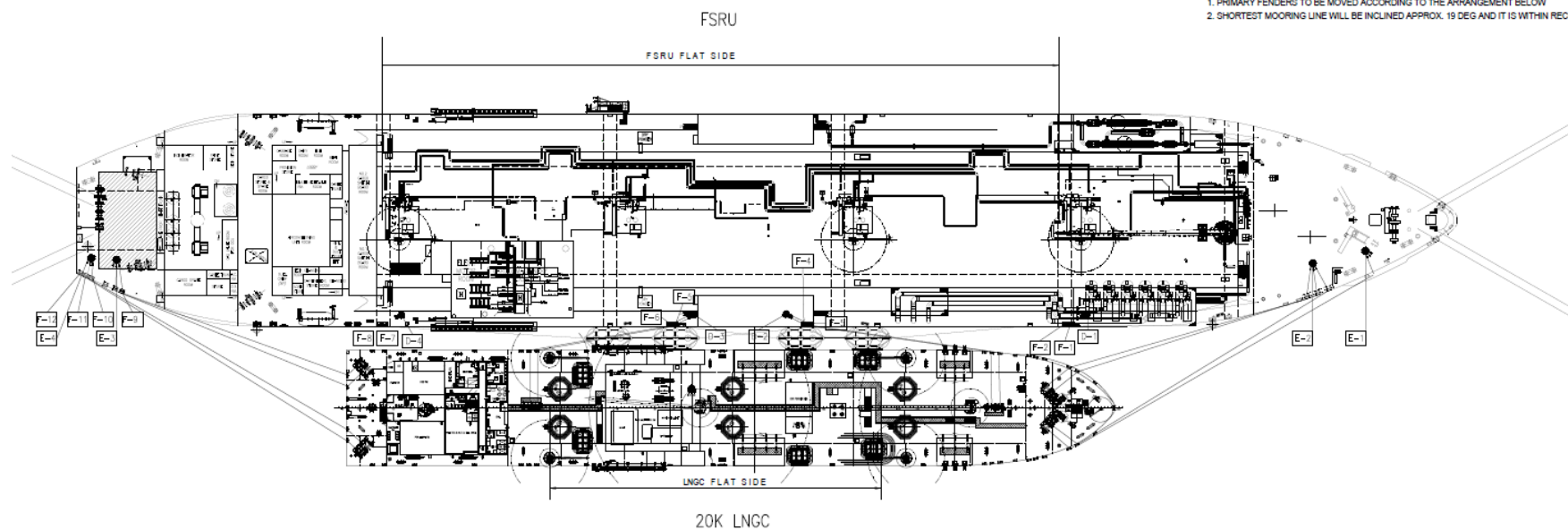

Figure 19 Proposed mooring plan with up to 20000 LNGC

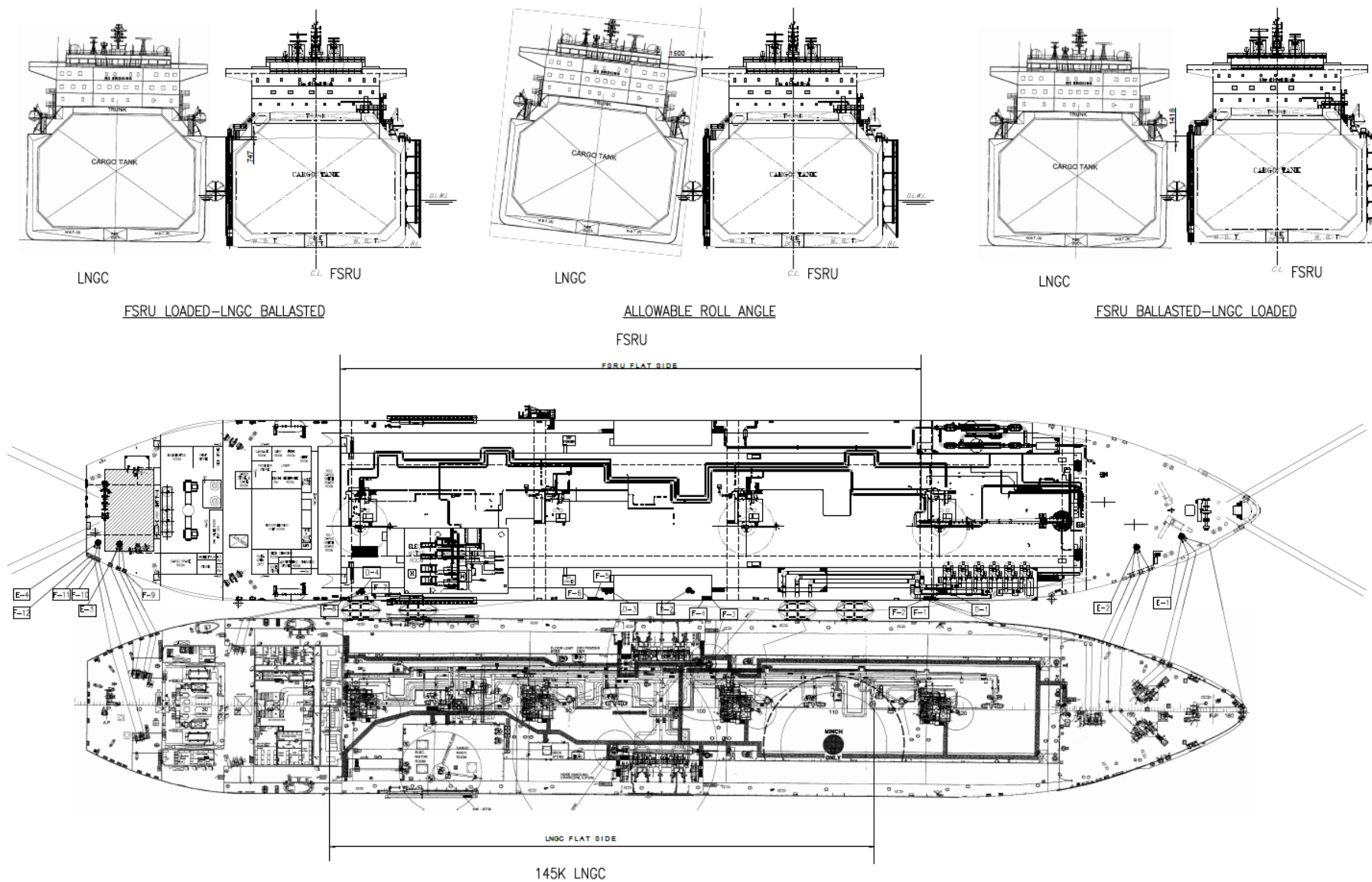

Figure 20 Proposed mooring plan with up to 145000 LNGC

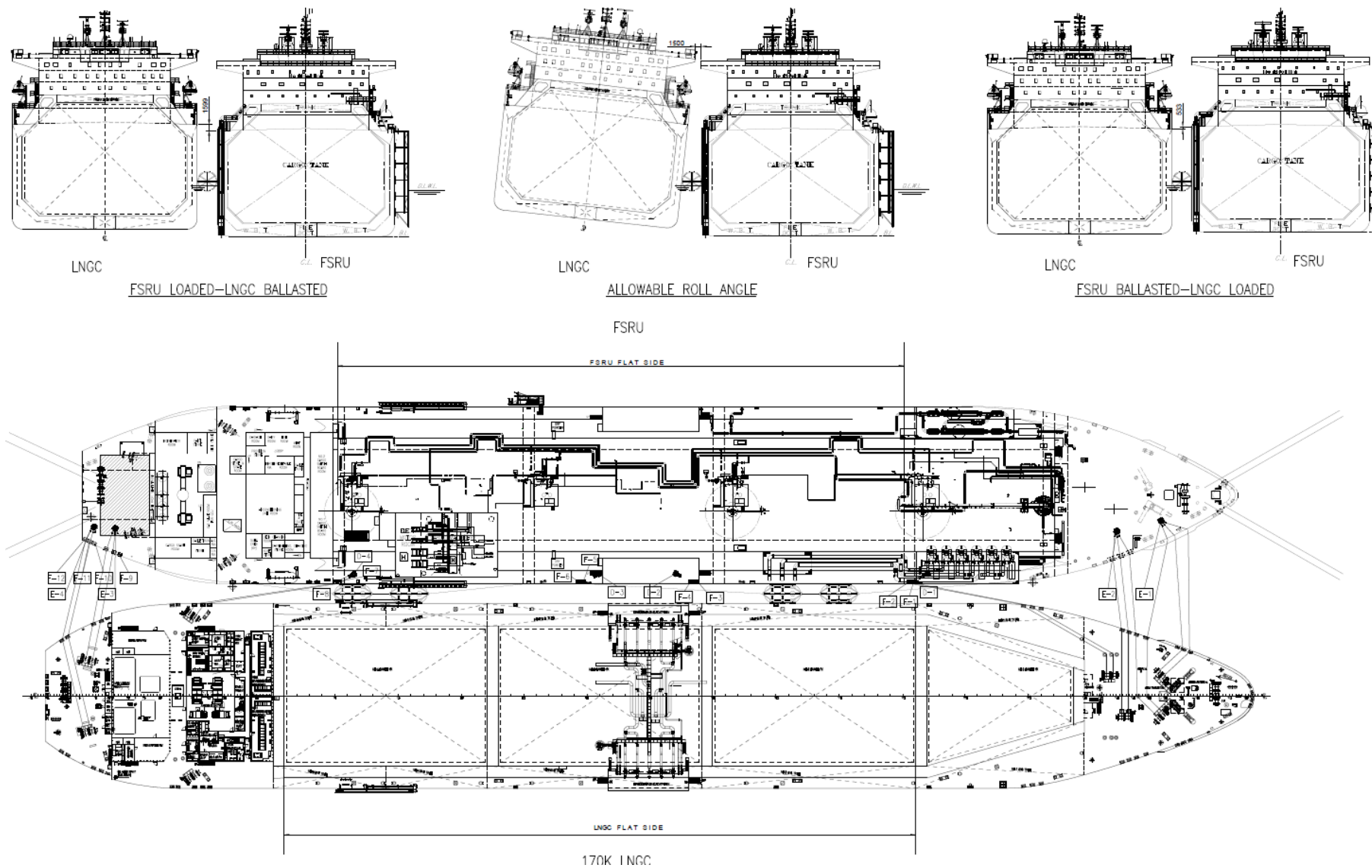

Figure 21 Proposed mooring plan with up to 170000 LNGC



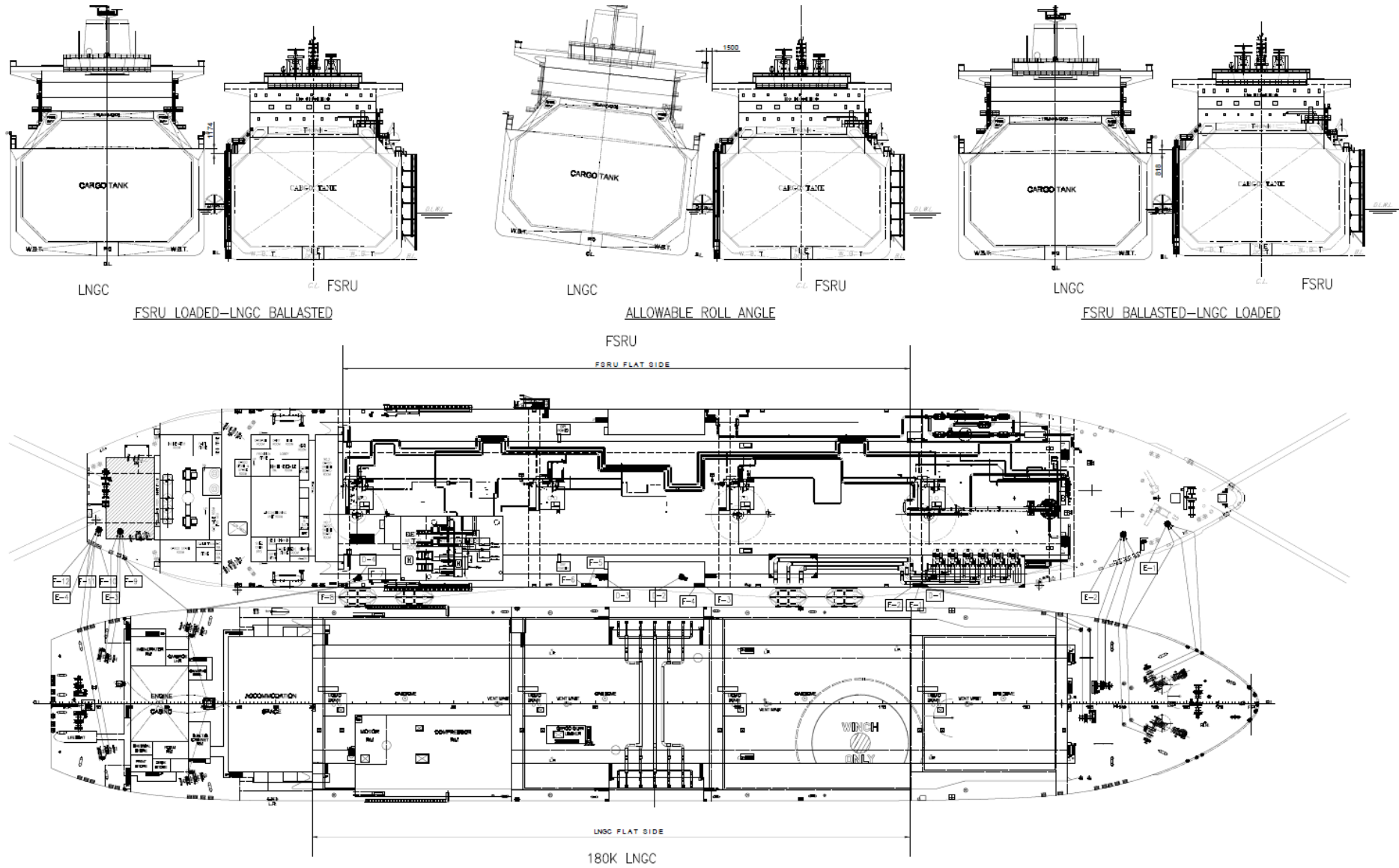

Figure 22 Proposed mooring plan with up to 180000 LNGC

## 6. Fender Mooring Arrangement Plan

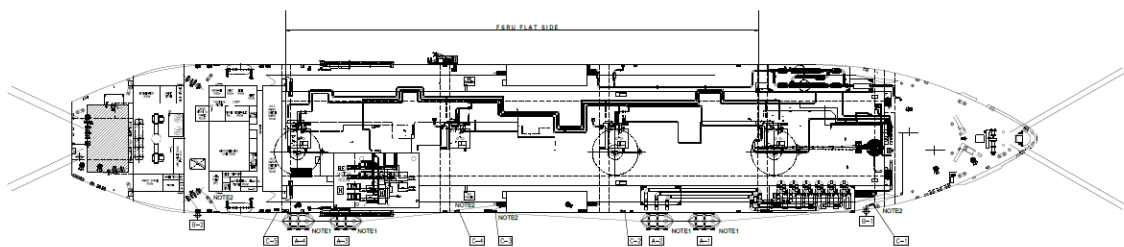
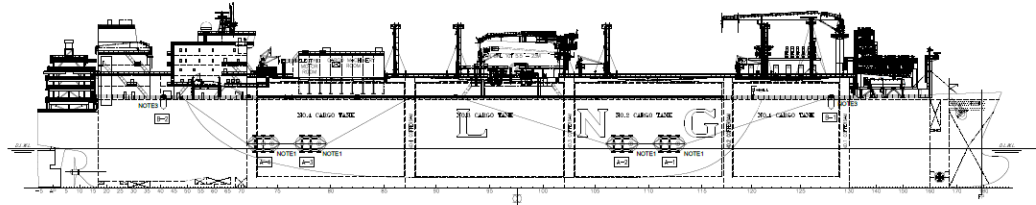

Figure 18 Primary fender position for receiving large LNGCs (145K-180K)

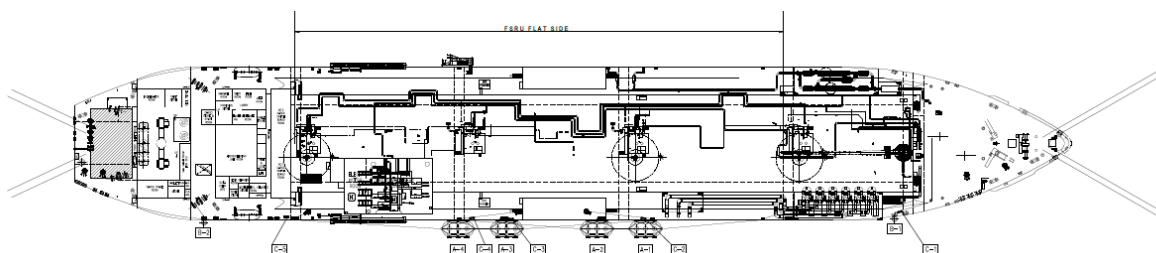
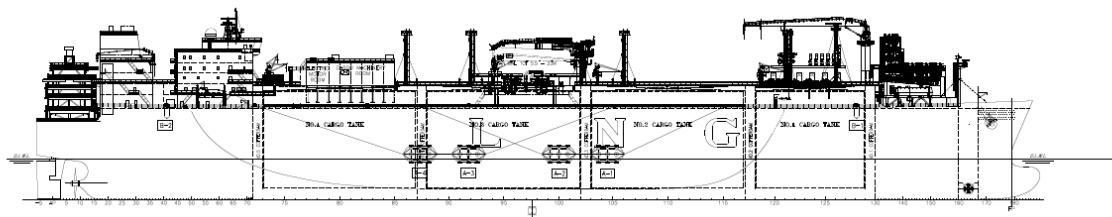

Figure 23 Primary fender position for receiving small LNGC carriers (3K-20K)

This page has been intentionally left blank

DYNAMARINE is located in:  
Athens / London / Singapore

---

Tel: (+30) 210 9628379  
(+30) 210 8941667

---

Email: [info@dynamarine.com](mailto:info@dynamarine.com)  
[www.dynamarine.com](http://www.dynamarine.com)

